



OWNER'S (OPERATOR'S) MANUAL
AND SAFETY INSTRUCTIONS
FOR KITO ELECTRIC CHAIN HOIST

ER SERIES

125kg through 5t capacity

Approved by CSA

ALWAYS KEEP THIS MANUAL FOR YOUR REFERENCE.

CONTENTS

1. DEFINITIONS	1
2. INTENDED PURPOSE	1
3. BEFORE USE	1
3.1 Safety summary	1
3.2 Safety instructions	2
3.2.1 Before use	2
3.2.2 While operation	2
3.2.3 After operation	3
3.2.4 Maintenance	3
3.2.5 Others	3
4. MAIN SPECIFICATIONS	4
4.1 Specifications	4
4.2 Mechanical classification (Grade) and life	5
4.3 Special features	9
5. PREPARATION AND CHECKING BEFORE USE	10
5.1 Assembly of the electric chain hoist Hook Suspension	10
(1) Attaching the chain container	10
(2) Lubricating the gear case	14
(3) Lubricating the load chain	15
(4) Checking chain alignment	15
5.2 Assembly of the electric chain hoist with motorized trolley	16
(1) Attaching the chain container	16
(2) Lubricating the gear case	16
(3) Lubricating the load chain	16
(4) Checking chain alignment	16
(5) Assembling trolley and connecting with hoist	16
(6) Mounting trolley to traversing rail	20
5.3 Wiring and installation of power supply	22
(1) Checking and changing wiring	22
(2) Wiring of power supply cable	24
(3) Installation of power supply cable	25
(4) Connection of power supply cable to electric power source	25
5.4 Trial run	29

6. OPERATION	31
6.1 Intended purpose of hoist operation.....	31
6.2 Safety working environment.....	31
6.3 Electric chain hoist.....	31
6.4 Electric chain hoist with motorized trolley	32
6.4.1 Operation.....	32
6.4.2 Precautions in usage.....	33
7. MAINTENANCE	34
7.1 Lubrication	34
7.1.1 Gear lubrication.....	34
7.1.2 Load chain lubrication	34
7.2 Chain replacement.....	34
7.2.1 Single fall chain	35
7.2.2 Double falls chain	35
7.3 Inspection	37
7.3.1 Inspection classification.....	37
7.3.2 Daily inspection	37
7.3.3 Periodic inspection.....	37
7.3.4 Occasionally used hoist.....	37
7.3.5 Inspection record.....	38
7.3.6 Inspection procedure	38
8. TROUBLESHOOTING.....	50
9. WARRANTY.....	51

1. DEFINITIONS

⚠ DANGER : indicates an imminently hazardous situation which, if not avoided, **will** result in **death or serious injury**.

: indicates a potentially hazardous situation which, if not avoided, **could** result in **death or serious injury**.

⚠ WARNING : indicates a potentially hazardous situation which, if not avoided, **may** result in **minor or moderate**

⚠ CAUTION **injury**. It may also be used to alert against unsafe practices.

Capacity : The measuring weight in this manual is indicated in metric tons. The values from 125 to 500 are indicated in kg, whereas all other values are indicated in t(tonne).

2. INTENDED PURPOSE

KITO electric chain hoist is designed for vertically lifting, lowering and horizontally carrying loads by means of switching the pendant push button under normal atmospheric conditions of the workplace.

3. BEFORE USE

3.1 Safety summary

Danger exists when heavy loads are transported, particularly when the equipment is not being used properly or is poorly maintained. Because accidents and serious injury could result, special safety precautions apply to the operation, maintenance and inspection of the KITO electric chain hoist ER series.

⚠ WARNING

NEVER use a hoist for lifting, supporting or transporting people.

NEVER lift or transport loads over or near people.

NEVER lift more than the rated capacity which is shown on the hoist name plate.

ALWAYS let people around you know when a lift is about to begin.

ALWAYS read the operation and safety instructions.



Remember proper rigging and lifting techniques are the responsibility of the operator. Check all applicable safety codes, regulations and other applicable laws for further information about the safe use of your hoist.

3.2 Safety instructions

⚠ WARNING

3.2.1 Before use

- ALWAYS** allow the instructed (trained in safety and operation) people to operate the hoist.
- ALWAYS** check the hoist before daily use according to the "Daily inspection" (Refer to 7.3.2).
- ALWAYS** make sure that the chain length is long enough for the intended work.
- ALWAYS** check that the hook latches work properly and replace missing or broken hook latches (Refer to 7.3).
- ALWAYS** check the brake before use (Refer to 7.3).
- ALWAYS** use two hoists which each has Capacity equal to or more than the load to be lifted whenever you must use two hoists to lift a load.
- ALWAYS** use KITO original chains or authorized chains.
- ALWAYS** check and keep the surface of the load chain oiled.
- NEVER** use a hoist without a hoist name plate.
- NEVER** use a modified or deformed hook.
- NEVER** use a hoist in explosive atmosphere.

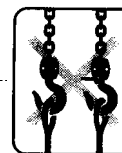

3.2.2 While operation

- ALWAYS** make sure that the load is properly seated in the hook.
- ALWAYS** tighten the slack out of the chain and sling when starting a lift to prevent a sudden loading.
- ALWAYS** avoid excessive inching operation.
- ALWAYS** make sure the hoist motor completely stops before reversing.
- ALWAYS** use a hoist within the "Duty rating", ED% or time rating.
- NEVER** operate unless the load is centered under the hoist.
- NEVER** use the hoist chain as a sling.
- NEVER** use a twisted, kinked, damaged or stretched load chain.
- NEVER** swing a suspended load.



- NEVER** support a load on the tip of the hook.
- NEVER** contact the load chain over an edge.
- NEVER** weld or cut a load suspended by a hoist.
- NEVER** use the hoist chain as a welding electrode.
- NEVER** operate a hoist if chain jumping or excessive noise occurs.
- NEVER** use the capsized load chain.
- NEVER** use the friction clutch or limit switch regularly, which may cause several damage to the hoist and cause serious injury.
- NEVER** pull the push button cord.

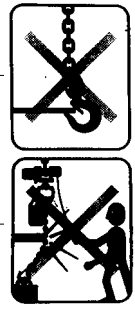

3.2.3 After operation

- NEVER** leave a suspended load unattended.

3.2.4 Maintenance

- ALWAYS** let the qualified service personnel inspect the hoist periodically (Refer to 7.3.3).
- ALWAYS** oil the load chain (Refer to 7.2).
- NEVER** splice, add and weld a load chain for extension.
- NEVER** touch live electrical parts.
- NEVER** adjust the friction clutch.

3.2.5 Others

- ALWAYS** consult the manufacturer or your dealer if you plan to use a hoist in an excessively corrosive environment (salt water, sea air and/or acid, explosive environment or other corrosive compounds, etc.).

4. MAIN SPECIFICATIONS

4.1 Specifications

The following specifications are common to all KITO ER series electric chain hoists, Capacity 5t or less.

Table 4-1 Specifications

Item		Specification		
Working temperature range (°C)		-20 to +40 (-4 to +104°F)		
Working humidity range (%)		85 or less		
Protection	Hoist	IP 55		
	Push button	IP 65		
Electric power supply		Three phase	60Hz	220V 440V 575V
Chain size & Chain fall	Capacity (kg or t)	Nominal diameter (mm)	Pitch (mm)	Chain fall
	125(H) 250(S)	5	15.0	1
	250(H) 500(L)、500(S)	6.3	19.0	1
	1(L)、1(M)、1(S)	8	24.0	1
	1.5(S)、2(L)、2(M)、2(S)	10	30.0	1
	2. 5(S)	11.2	34.0	1
	3(C)	10	30.0	2
	3(L)、3(S)	12.5	38.0	1
	5(L)	11.2	34.0	2

Remarks : (1) Contact KITO or an authorized KITO dealer for information on using the hoist outside the working temperature or humidity range.

(2) For dimensions and further details, refer to the latest catalogue.

(3) For larger Capacity hoists (7.5t and larger), refer to the ERML-9806-MC manual.

(4) The letters (L), (M), (S) and (H) show low, medium, standard and high speed models respectively.

4.2 Mechanical classification (Grade) and life

Safety and life for electric chain hoists are guaranteed only when the said equipment is operated in accordance with the prescribed grade.

KITO electric chain hoists ER series are designed for grade 1Am, 2m in the FEM regulations (FEM 9.511) and M4, M5 in the ISO regulations (ISO 4301) shown in Table 4-2. The grades are provided in Table 4-3 to Table 4-6.

Average daily operating time and total operating time are determined by load distribution.

Table 4-2

CODE	Capacity (kg or t)	GRADE	
		FEM	ISO
ER001H	125	2m	M5
ER003S	250	2m	M5
ER003H	250	2m	M5
ER005L	500	1Am	M4
ER005S	500	2m	M5
ER010L	1	1Am	M4
ER010M	1	1Am	M4
ER010S	1	2m	M5
ER015S	1.5	2m	M5
ER020L	2	1Am	M4
ER020M	2	1Am	M4
ER020S	2	2m	M5
ER025S	2.5	1Am	M4
ER030C	3	1Am	M4
ER030L	3	1Am	M4
ER030S	3	1Am	M4
ER050L	5	1Am	M4
ER075S	7.5	1Am	M4
ER100L	10	1Am	M4
ER100S	10	1Am	M4
ER150S	15	1Am	M4
ER200S	20	1Am	M4

Table 4-3 1Am(FEM)

Load spectrum (Load distribution)	Definitions	Cubic mean value	Average daily operating time(h)	Total operating time(h)
1 (light)	Mechanisms or parts thereof, usually subject to very small loads, seldom to maximum loads.	$k \leq 0.50$	2 - 4	6300
2 (medium)	Mechanisms or parts thereof, usually subject to small loads, but rather often to maximum loads.	$0.50 < k \leq 0.63$	1 - 2	3200
3 (heavy)	Mechanisms or parts thereof, usually subject to medium loads and frequently to maximum loads.	$0.63 < k \leq 0.80$	0.5 - 1	1600
4 (very heavy)	Mechanisms or parts thereof, mainly subject to maximum or almost maximum loads.	$0.80 < k \leq 1.00$	0.25 - 0.5	800

Table 4-4 2m(FEM)

Load spectrum (Load distribution)	Definitions	Cubic mean value	Average daily operating time(h)	Total operating time(h)
1 (light)	Mechanisms or parts thereof, usually subject to very small loads, seldom to maximum loads.	$k \leq 0.50$	4 - 8	12500
2 (medium)	Mechanisms or parts thereof, usually subject to small loads but rather often to maximum loads.	$0.50 < k \leq 0.63$	2 - 4	6300
3 (heavy)	Mechanisms or parts thereof, usually subject to medium loads and frequently to maximum loads.	$0.63 < k \leq 0.80$	1 - 2	3200
4 (very heavy)	Mechanisms or parts thereof, mainly subject to maximum or almost maximum loads.	$0.80 < k \leq 1.00$	0.5 - 1	1600

Table 4-5 M4(ISO/JIS)

state of loading / load rate	Definitions	Nominal load spectrum factor (Km)	Total running time (h)	Total operating time(h)
1 (light)	ISO; Mechanisms subjected very rarely to the maximum load and, normally, to light loads	0.125	-	6300 / 6400
	JIS; Use at about 1/3 of rated load usually and at rated load rarely	-	2 - 4	
2 (medium / middle)	ISO; Mechanisms subjected fairly frequently to the maximum load but, normally, to rather moderate loads	0.25	-	3200
	JIS; Use at about 1/3 to 2/3 of rated load usually and at rated load at times	-	1 - 2	
3 (heavy)	ISO; Mechanisms subjected frequently to the maximum load and, normally, to loads of heavy magnitude	0.50	-	1600
	JIS; Use at 2/3 of rated load or over usually and at rated load many times	-	0.5 - 1	
4 (very heavy)	ISO; Mechanisms subjected regularly to the maximum load	1.00	-	800
	JIS; Use at rated load or near load almost all the time	-	0.25 - 0.5	

Table 4-6 M5(ISO/JIS)

state of loading / load rate	Definitions	Nominal load spectrum factor (Km)	Total running time (h)	Total operating time(h)
1 (light)	ISO; Mechanisms subjected very rarely to the maximum load and, normally, to light loads	0.125	-	12500
	JIS; Use at about 1/3 of rated load usually and at rated load rarely	-	4 - 8	
2 (medium / middle)	ISO; Mechanisms subjected fairly frequently to the maximum load but, normally, to rather moderate loads	0.25	-	6300 / 6400
	JIS; Use at about 1/3 to 2/3 of rated load usually and at rated load at times	-	2 - 4	
3 (heavy)	ISO; Mechanisms subjected frequently to the maximum load and, normally, to loads of heavy magnitude	0.50	-	3200
	JIS; Use at 2/3 of rated load or over usually and at rated load many times	-	1 - 2	
4 (very heavy)	ISO; Mechanisms subjected regularly to the maximum load	1.00	-	1600
	JIS; Use at rated load or near load almost all the time	-	0.5 - 1	

4.3 Special features

(1) Motor brake

The motor brake is unique with the pull rotor braking structure and its powerful braking force enables the hoist to support the load surely. Non-asbestos material is used in the motor brake.

(2) Hook and hook latch

The hook is drop-forged from the special carbon steel and will not fracture but will open gradually when overloaded. In addition, the hook is equipped with a hook latch which acts to keep the load captive in the hook under slack load conditions.

(3) Limit switch

An electric limit switch mechanism is employed to prevent overwinding.

Refer to table 4-1 to make sure which models are equipped with the limit switch as a standard or optional feature.

(a) Upper limit switch

The hoist is automatically stopped instantly in case of overlifting.

(b) Upper /lower limit switch

The hoist is automatically stopped instantly in case of overwinding.

(4) Friction clutch

The friction clutch mechanism, originally developed by KITO, enables the motor to idle when excessively overloaded or overwinded. Thus the mechanism prevents damage due to overload or overwind. Non-asbestos material is used in the friction clutch.

(5) Emergency stop device

This device is an option for the electric chain hoist, a standard for the electric chain hoist with motorized trolley.

The mushroom type button, in red at the uppermost position on the pendant switch, is used stop the hoist and trolley in an emergency situation. When pressed, power to the equipment is shut off and the button locks automatically. Turn it to the right to release the locks and to enable re-start.

CAUTION

The set value (1.25 times or more) may change if loads over the WLL are lifted often.

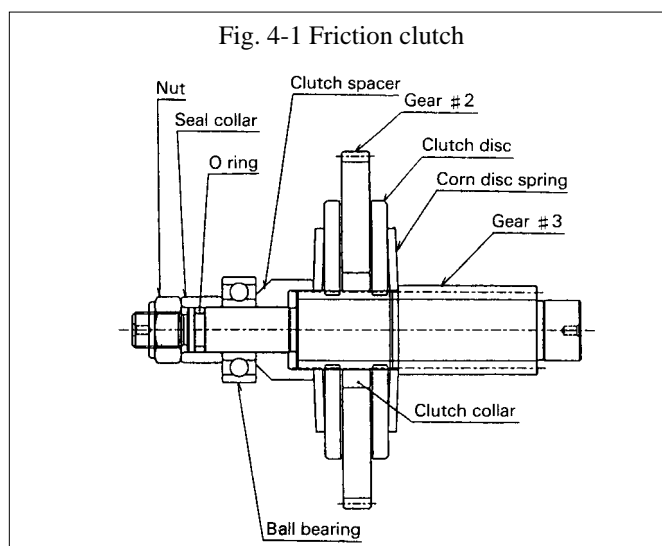

5. PREPARATION AND CHECKING BEFORE USE

5.1 Assembly of the electric chain hoist - Hook Suspension

⚠ WARNING

ALWAYS make sure that the supporting structures and load-attaching device are strong enough to hold the weight of the load and hoist.

(1) Attaching the chain container

Remark : For large Capacity hoists (7.5t and larger), refer to the ERML-9806-MC manual.

The chain container stores the load chain when a load is lifted. The installation procedure is as shown in Fig.5-1, Fig.5-2 and Fig.5-3. Check that the stopper is properly attached to the 3rd link from the no load side end, and also for 030C and 050L(D), attach the stopper to the 6th link from the load side end for the upper limit switch; to the 8th link for the upper-lower limit switch. Feed the chain into the container from the free end, avoiding twists and links. To avoid lumping and twisting, **NEVER** put all the chain into the container at once. Lumped or twisted chain may activate the limit switch (in case of the hoist equipped with limit switch) and stop the hoist during lowering.

Additionally, each chain container indicates the maximum length of the load chain stored in the container. It is very dangerous to use a chain container with a storage capacity less than the length of the load chain, if all of the necessary chain can not be stored in the container, and limit switch will not operate properly. Determine the length of load chain and select a chain container with proper capacity.

Remark : For the relationship between chain length and chain container, refer to the periodic inspection tables in 7.3.6 "Inspection procedure".

1. Plastic chain container

For B size

Hold the chain container and chain container spring against the hoist in the orientation shown in Fig.5-1, and slide the socket bolt through all holes on the chain container, chain guide A and spring until protruding on the other end.

For C,D size

Hook the chain container suspender on the spring pin on the no load side of chain guide A.

Turn the chain container suspender until fitting inside the opening on chain container P as shown in Fig.5-2, and press upward until fitting snugly against the upper inside surface of chain container P as shown in the figure.

Slide the socket bolt through the hole on chain container P and tightly lock on the other end with the lever nut.

Note : Make sure the socket bolt passes underneath the chain container suspender and securely locks both chain container P and the chain container suspender in place.

Hold the chain container spring over the chain container P, caring about the direction of the spring, and put the plain washers on both side of the spring and lock on the chain guide A with the socket bolt and the lever nuts.

▲ CAUTION

Remove the chain container P when you put down the hoist on the ground.

2. Chain container

Install to the hoist body as shown Fig 5-3.

Fig 5-1 Attachment of chain container P with name plate K :

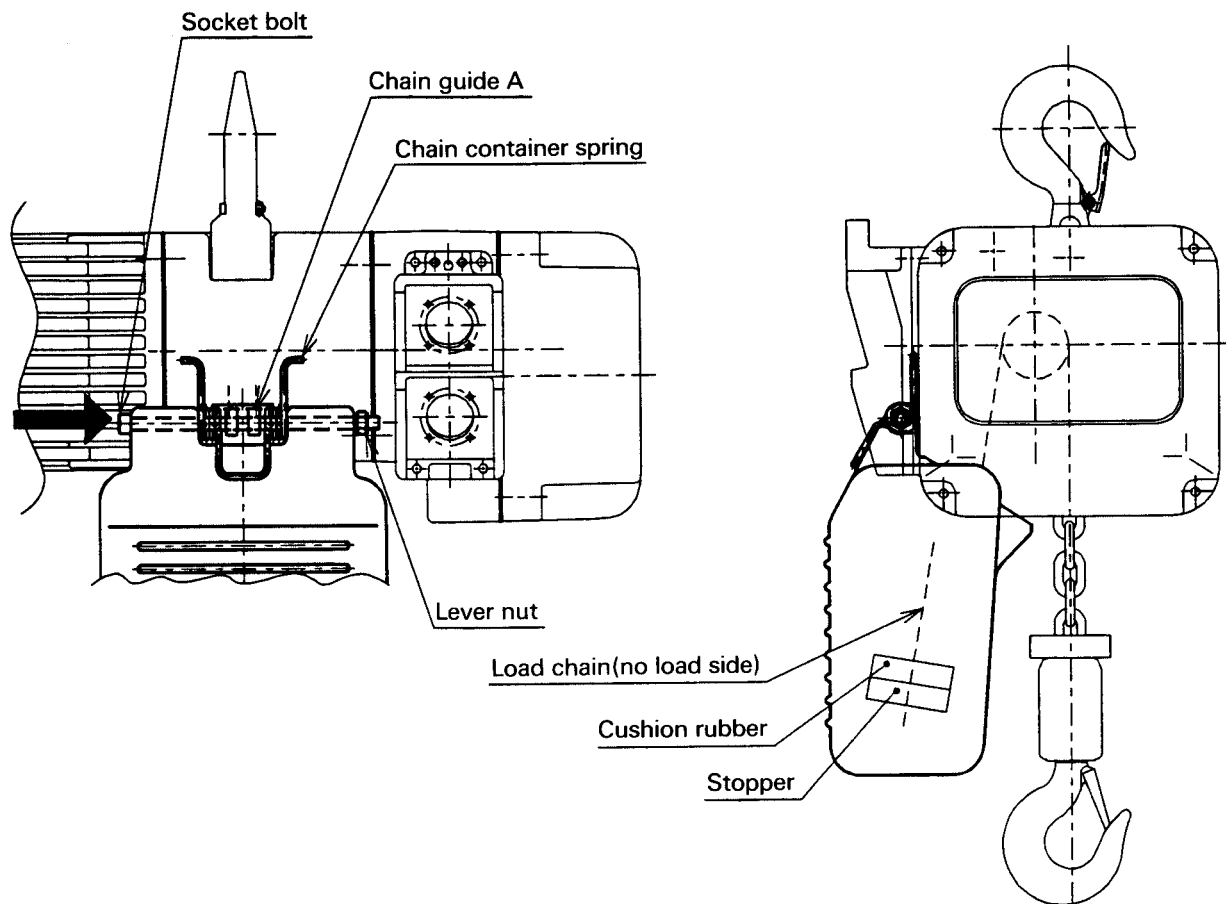

Fig 5-2 Attachment of chain container P with name plate K **C** or **D**

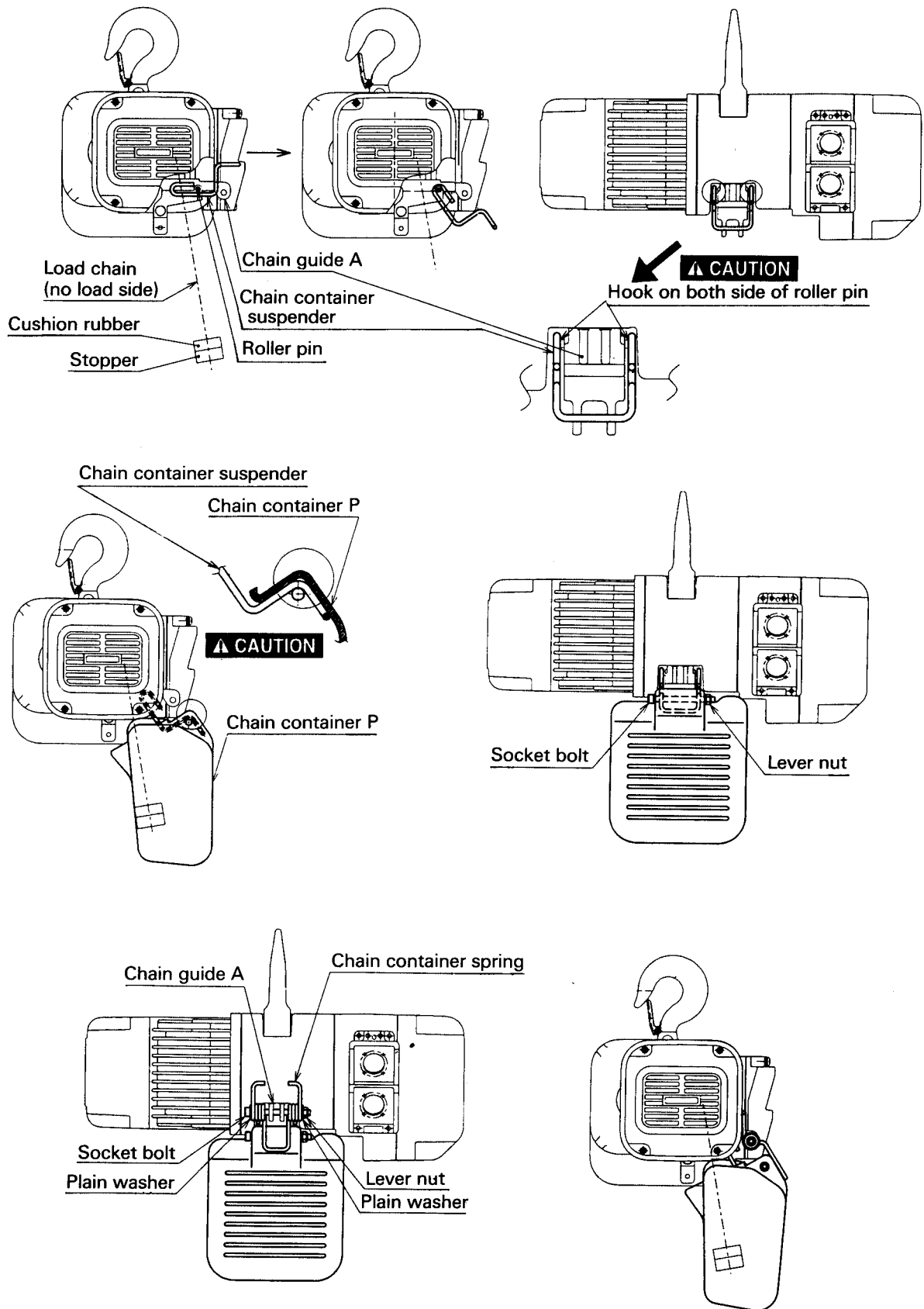
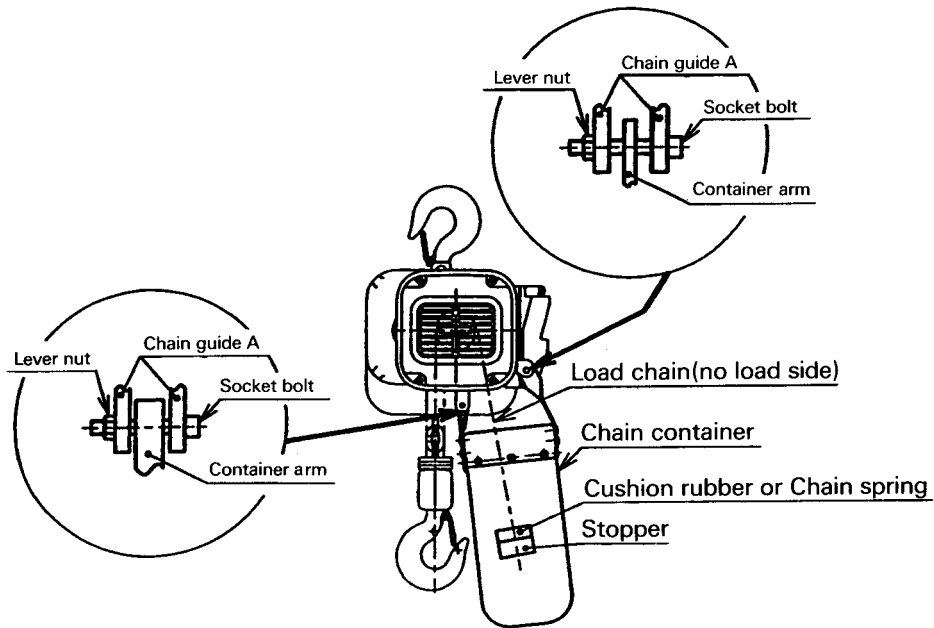

Fig 5-3 Attachment of chain container



If a chain container is not used, remove the stopper from the free end of the chain and secure to the 13th, 15th or 25th link from the free end as shown in Fig.5-4. Then attach the end link to the chain guide A with the chain end suspender except the 5t capacity with the end link directly attached to the chain guide A.

CAUTION

Using the lock nut (U nut), tighten it properly. Prevent deformation of the chain guide A caused by screwing it too much.

When a chain container is used, the stopper is attached to the 3rd link from the free end of the load chain. Therefore, the lift is slightly shorter when a container is not used.

Fig 5-4 Attachment of chain to hoist body — No chain container

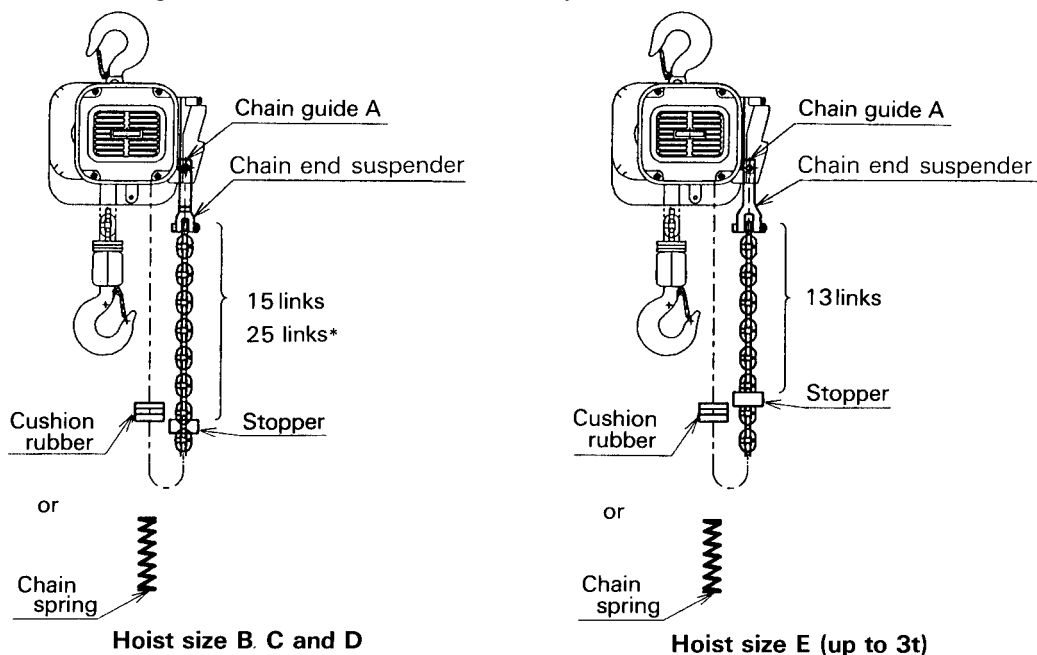

*For 125kg capacity with the upper-lower limit switch and dual speed, attach the stopper to the 25th link.

(2) Lubricating the gear case

Remark : For larger Capacity hoists (7.5t and larger), refer to the ERML-9806-MC manual.

The gear case does not contain oil at time of delivery. Remove the oil plug and pour all the gear oil, packed with the hoist, into the gear case by using the pot nozzle, and reinstall oil plug.

The specified gear oil is allowed for the ER hoist.

Table 5-1 Gear oil quantity

Hoist Size	Oil quantity (liters)
B	0.7
C	1.0
D	1.7
E	3.0

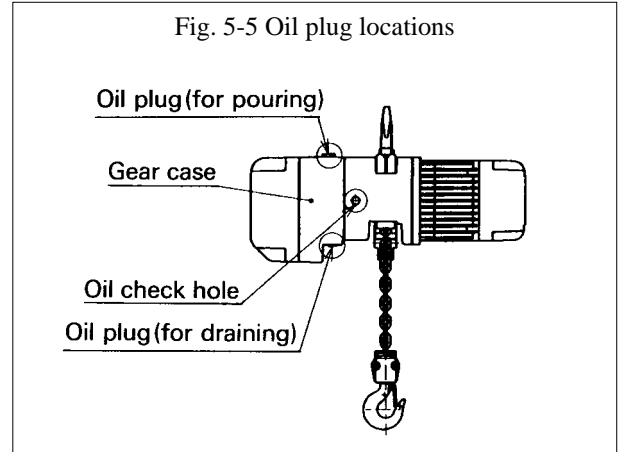

CAUTION

Gear oil is different between friction clutch and mechanical brake combined with a friction clutch (option).

Use one of the below listed gear oils.

(1) Friction clutch

- a) KITO standard oil : Bonnoc M260 (NIPPON MITSUBISHI OIL)
- b) Recommended oil : Meropa 320 (TEXACO)
- c) Recommended oil : Meropa 320 (CALTEX)

(2) Mechanical brake combined with a friction clutch (option).

- a) KITO standard oil : Farm Gear B (NIPPON MITSUBISHI OIL)
- b) Recommended oil : Meropa No.68 (TEXACO)

Remark : For hoist applications in temperatures below -20°C (-4°F), contact KITO or authorized KITO dealer for special instructions regarding gear oil.

Handling the oil cap for the mechanical brake combined with friction clutch

In case of the mechanical brake combined with friction clutch, the oil cap as shown in Fig.A is located on the side of the gear casing.

Before hooking up the hoist, pull the oil cap arm to expose a few mm of the inner part of it or pull off it to maintain the air path to the outside of the gear casing.

When transferring the hoist, unhook the hoist and push it back into the original position because inclining the hoist too much while transferring may cause oil leakage.

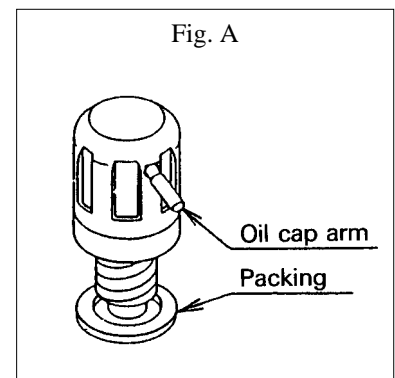

(3) Lubricating the load chain

To lubricate the chain, lightly coat the chain with machine oil or gear oil. Regular lubrication will help prevent wear and corrosion, which will extend the service life of the chain. Be sure oil is applied to surfaces of the chain.

(4) Checking chain alignment

Remark : For larger capacity hoists (7.5t and larger), refer to the ERML-9806-MC manual.

ER series hoist have double chain fall models for 3t or 5t capacity. Ensure that the bottom hook on the double fall models is not capsized. If it is capsized, restore it to normal and make sure the welds on the chain links are in alignment. Never try to suspend a load on a hoist with twisted chain.

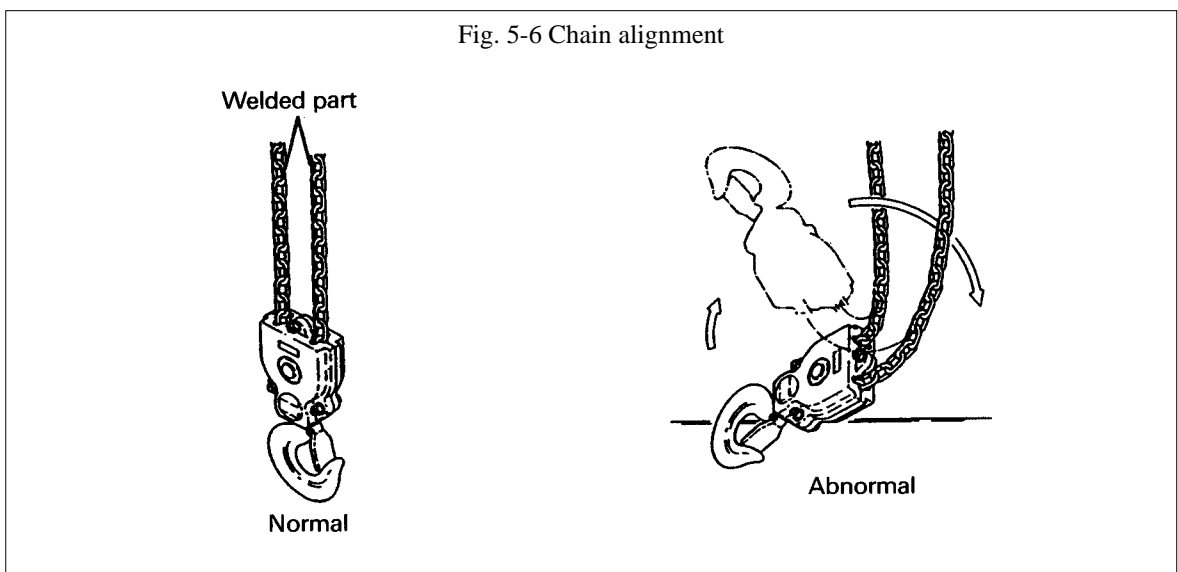

⚠ CAUTION

Check for twisting in the chain.

5.2 Assembly of the electric chain hoist with motorized trolley

For the following four items (1), (2), (3) and (4), refer to the same items in 5.1 "Assembly of the electric chain hoist - Hook Suspension".

- (1) Attaching the chain container
- (2) Lubricating the gear case
- (3) Lubricating the load chain
- (4) Checking chain alignment
- (5) Assembling trolley and connecting with hoist

Remark : For larger Capacity hoists (7.5t and larger), refer to the ERML-9806-MC manual.

(a) Assembling trolley

- 1) Insert the suspension shaft to side plate G and lock it with the suspension shaft bolt, slotted nut and split pin. Securely bend both branches of the split pin after insertion.
- 2) Insert the fixing shaft to side plate G and lock it with the split pin. Securely bend both branches of the split pin after insertion.
- 3) Insert the suspension shaft with the inner adjusting spacers as shown in Table 5-2.
- 4) Insert the suspension shaft and fixing shaft into the suspender T attached to hoist body. Make sure the nameplates of the hoist and trolley are facing in the same direction.
- 5) Insert more spacers into the suspension shaft and insert the suspension shaft and fixing shaft onto side plate S.
- 6) Put the outer adjusting spacers on the suspension shaft. Insert the shaft stopper pin into suspension shaft and also insert split pin into shaft stopper pin. Insert shaft stopper pin so that split pin is to the left when seen from the front side of trolley switch box.

Table 5-2 Adjusting spacer arrangement for Low Head Suspension

		Number of Adjusting Spacers																																																			
Capacity(t)	Beam flange width (in)	2 5/16	2 1/2	2 7/8	3	3 1/4	3 9/16	3 7/8	3 15/16	4	4 3/16	4 5/16	4 7/16	4 11/16	4 15/16	5	5 3/16	5 5/16	5 3/8	5 5/8	5 11/16	6	6 1/8	6 5/16	6 7/16	6 11/16	6 7/8	7	7 1/16	7 1/4	7 7/8	8	8 7/16	8 11/16	9	9 1/8	9 7/8	10	10 1/8	10 1/4	10 3/8	10 1/2	11	11 1/8	11 1/4	11 3/8	11 5/8	11 3/4	11 13/16	11 7/8	12		
		(mm)	58	64	73	75	82	90	98	100	102	106	110	113	119	125	127	131	135	137	143	149	150	153	155	160	163	170	175	178	180	181	184	185	200	203	215	220	229	232	250	254	257	260	264	267	279	283	286	289	295	298	300
1	Thin spacer	Inner	1+2	2+3	4+4	1+0	1+2	2+3	0	1+0	1+1	2+2	2+3	3+4	4+4	4+1	5+1	2+2	3+3	4+4	4+1	1+1	2+2	2+3	3+0	4+4	4+1	1+1	1+2	4+4	5+0	2+3	3+4	1+1	1+2	4+0	1+1	1+2	2+2	2+3	3+3	1+1	1+2	2+2	2+3	3+0	4+0	4+1	4+2				
		Outer	5	3	0	7	5	3	8	7	5	4	3	1	0	3	2	4	2	0	3	6	4	3	5	0	3	6	5	0	3	3	1	6	5	4	6	5	4	3	2	6	5	4	3	5	4	3	2				
	Thick spacer	Inner	0			1+1						1+2		2+2			3+3			3+4		3+3		3+4		0		0+1		1+1		2+2		2+3		3+3			4+4		4+5												
		Outer	3			3						1		0			2		1			3		2		3		2		9		8		7		5		4		3			1		0								
	Fixing spacer	Inner																0																																			
		Outer																2																																			
	Thick spacer L	Inner	0			1+1																																															
		Outer	2			0																																															
	2	Thin spacer	Inner	1+2	2+3	3+4	0	1+0	1+1	1+2	2+2	3+3	4+4	4+1	1+1	1+1	1+2	2+2	3+3	4+0	4+1	1+1	1+2	2+2	3+3	4+4	1+4	1+1	1+2	4+4	1+0	2+3	3+3	4+1	1+1	4+4	4+1	5+1	4+3	2+3	3+3	4+1	1+2	2+2	2+3	3+3	3+4	4+4	4+1	5+1			
			Outer	5	3	1	8	7	6	5	4	2	0	7	6	5	4	2	4	3	6	5	4	2	0	3	6	5	0	7	3	2	3	6	0	3	2	1	3	2	3	5	4	3	2	1	0	3	2				
		Thick spacer	Inner	0			1+1						1+2		2+2			3+2		0		1+1		1+2		2+2		2+3		3+3		3+4		4+4			4+5																
			Outer	3			1						0		1			0		9		7		6		5		4		3		2		1			0																
Fixing spacer		Inner																1+1																																			
		Outer																0																																			
Thick spacer L		Inner	0			1+1																																															
		Outer	2			0																																															
3		Thin spacer	Inner	1+2	2+3	3+4	0	1+0	1+1	1+2	2+2	3+3	4+4	4+1	1+1	1+1	1+2	2+2	3+3	4+0	4+1	1+1	1+2	2+2	3+3	4+4	1+4	1+1	1+2	4+4	1+0	2+3	3+3	4+1	1+1	4+4	4+1	5+1	4+3	2+3	3+3	4+1	1+2	2+2	2+3	3+3	3+4	4+4	4+1	5+1			
			Outer	5	3	1	8	7	6	5	4	2	0	7	6	5	4	2	4	3	6	5	4	2	0	3	6	5	0	7	3	2	3	6	0	3	2	1	3	2	3	5	4	3	2	1	0	3	2				
		Thick spacer	Inner	0			1+1						1+2		2+2			3+2		0		1+1		1+2		2+2		2+3		3+3		3+4		4+4			4+5																
			Outer	3			1						0		1			0		9		7		6		5		4		3		2		1			0																
	Fixing spacer	Inner																1+1																																			
		Outer																0																																			
	Thick spacer L	Inner	0			1+1																																															
		Outer	2			0																																															
	5	Thin spacer	Inner	0	1+0	1+1	1+2	2+2	3+3	0	1+0	1+1	2+2	3+3	4+0	4+1	1+1	1+2	2+3	3+0	4+4	4+1	5+1	4+3	4+4	1+0	2+3	3+4	1+1	1+2	4+4	1+1	1+2	2+2	2+3	3+3	5+1	1+2	2+2	2+3	4+3	4+4	4+0	4+1	5+1								
			Outer	8	7	6	5	4	2	8	7	6	4	2	4	3	6	4	3	5	0	3	2	1	0	7	3	1	6	5	0	6	5	4	3	2	5	4	3	1	0	4	3	2									
		Thick spacer	Inner	0			0+1						1+1		1+2		1+1		1+2		2+2		3+3		4+4		5+5		5+6		6+6			6+7																			
			Outer	3			2						1		0		1		0		10		9		7		5		3		2		1			0																	
Thick spacer L		Inner	0			1+1																																															
		Outer	2			0																																															

Remarks : (1) Description for inner spacers

For example, 0 + 1

0 : the number of spacers on the left side of the shaft

1 : the number of spacers on the right side of the shaft

(2) Adjustment of trolley width

Refer to (b) of 5.2 on the next page.

Adjust the dimensions by appropriately increasing or decreasing the number of inner or outer adjusting spacers, without strictly adhering to the number of adjusting spacers shown in the above table.

(3) Spacer arrangement example

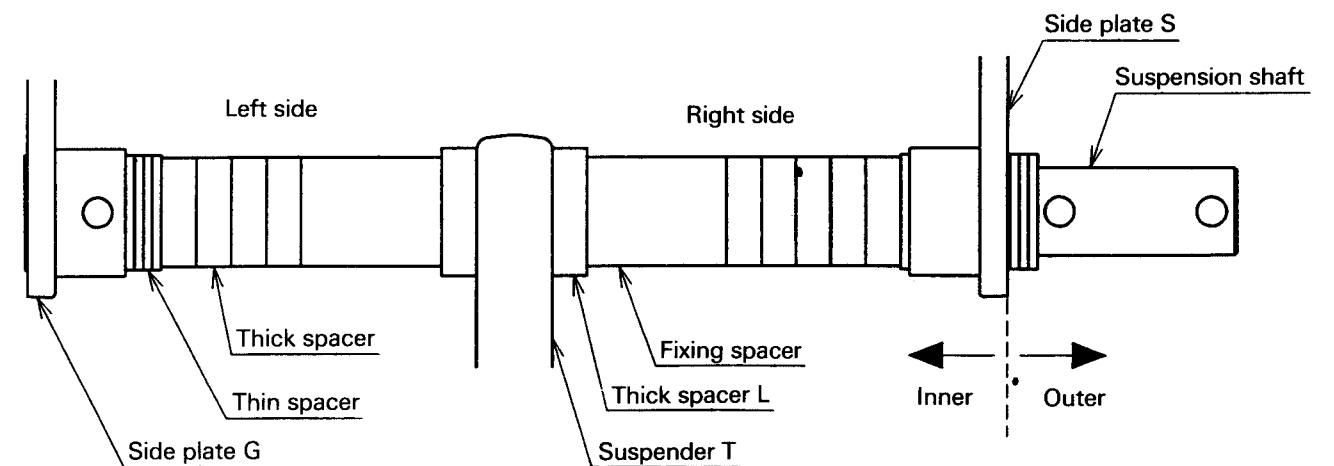
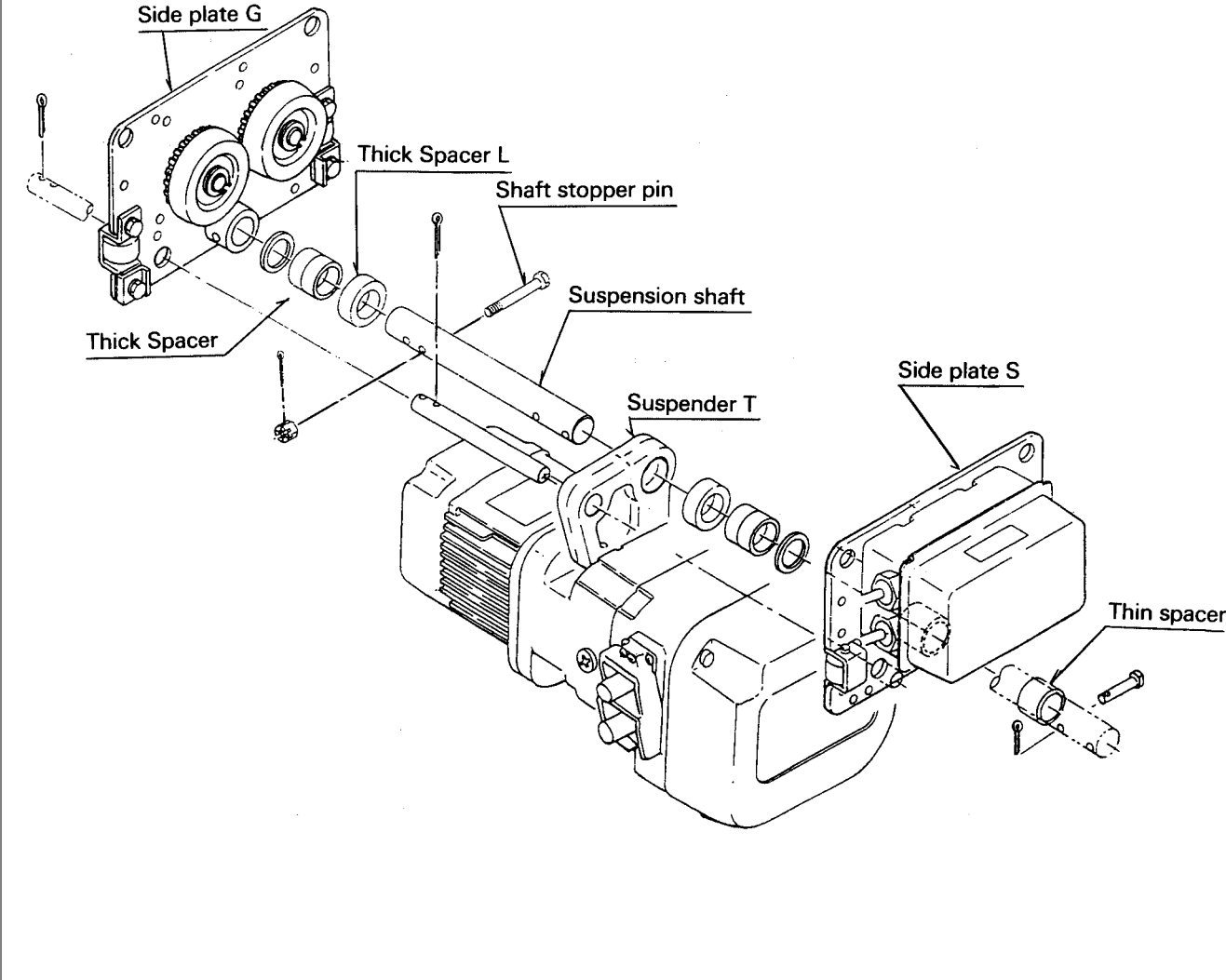

Table 5-2 Adjusting spacer arrangement for Lug Suspension

		Number of Adjusting Spacers																																																							
Capacity(t)	Beam flange width (in)	2 $\frac{5}{16}$	2 $\frac{1}{2}$	2 $\frac{7}{8}$	3	3 $\frac{1}{4}$	3 $\frac{9}{16}$	3 $\frac{7}{8}$	3 $\frac{15}{16}$	4	4 $\frac{3}{16}$	4 $\frac{5}{16}$	4 $\frac{7}{16}$	4 $\frac{11}{16}$	4 $\frac{15}{16}$	5	5 $\frac{3}{16}$	5 $\frac{5}{16}$	5 $\frac{3}{8}$	5 $\frac{5}{8}$	5 $\frac{11}{16}$	6	6 $\frac{1}{8}$	6 $\frac{5}{16}$	6 $\frac{7}{16}$	6 $\frac{11}{16}$	6 $\frac{7}{8}$	7	7 $\frac{1}{16}$	7 $\frac{1}{4}$	7 $\frac{7}{8}$	8	8 $\frac{7}{16}$	8 $\frac{11}{16}$	9	9 $\frac{1}{8}$	9 $\frac{7}{8}$	10	10 $\frac{1}{8}$	10 $\frac{1}{4}$	10 $\frac{3}{8}$	10 $\frac{1}{2}$	11	11 $\frac{1}{8}$	11 $\frac{1}{4}$	11 $\frac{3}{8}$	11 $\frac{5}{8}$	11 $\frac{3}{4}$	11 $\frac{13}{16}$	11 $\frac{7}{8}$	12						
		(mm)	58	64	73	75	82	90	91	98	100	102	106	110	113	119	120	125	127	131	135	137	143	149	150	153	155	160	163	170	175	178	180	181	184	185	200	203	215	220	229	232	250	254	257	260	264	267	279	283	286	289	295	298	300	302	305
5	Thin spacer	Inner														0	1+0	1+1	1+2	2+2	3+3	0	1+0	1+1	2+2	3+3	4+0	4+1	1+1	2+2	2+3	3+0	4+4	4+1	5+1	4+3	4+4	1+0	2+3	3+4	1+1	1+2	4+4	1+1	1+2	2+2	2+3	3+3	5+1	1+2	2+2	2+3	4+3	4+4	4+0	4+1	5+1
		Outer														8	7	6	5	4	2	8	7	6	4	2	4	3	6	4	3	5	0	3	2	1	0	7	3	1	6	5	0	6	5	4	3	2	5	4	3	1	0	4	3	2	
	Thick spacer	Inner														0			1+1			1+2		2+2		2+3		2+2		2+3		3+3		4+4		5+5			6+6			6+7		7+7			7+8										
		Outer														5			3			2		1		0		1		0		10		9		7		5			3			2		1			0								

Note: The arrangement for 1t to 3t is compatible with the low head suspension. Refer also to Table 5-2 for low head suspension.

Fig. 5-7 Assembling trolley and hoist



(b) Adjusting trolley width

Adjust the trolley width for the following proper clearance referring to Fig.5-8.

The proper "A" dimension is measured when both side plates are spread fully outward.

The "A" dimension is :

Rail flange width (B) + 4 mm approximately

If necessary to obtain the above "A" dimension, increase or decrease the number of adjusting spacers irrespective of the quantities in Table 5-2.

After obtaining the proper "A" dimension, insert the split pin into the shaft stopper pin and securely bend both branches of the split pin.

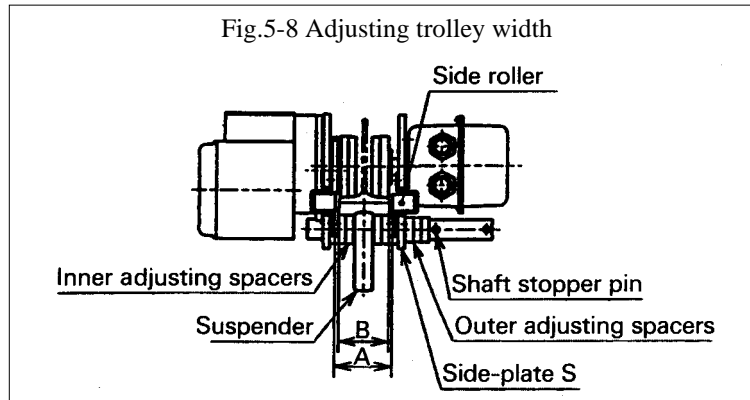

⚠ WARNING

ALWAYS fasten the slotted nut firmly, then insert and bend the split pin completely.

(6) Mounting trolley to traversing rail

Remark : For larger Capacity hoists (7.5t and larger), refer to the ERML-9806-MC manual.

(a) Mounting to traversing rail .

- 1) Slide the trolley with an electric chain hoist connected onto the traversing rail from the rail end. This is the most convenient and recommended way.
- 2) When the connected unit can not be mounted onto the rail sliding from the rail end, follow the next steps referring to Fig.5-9.
 - a) Remove the stopper pin from hole A and insert it into hole B of the suspension shaft. Reinsert and bend it fully.
 - b) With the side plates S and G spread outward, lift the trolley until the track wheels are on the same level of the rail surface (tread), and place the track wheels of side plate G on the rail tread.
 - c) Holding the side plate G securely so that it does not come off the rail, push the side plate S to put its wheels onto the rail tread.
 - d) Remove the stopper pin from hole B and insert it into hole A, and bend the split pin securely.

⚠ WARNING

Never use the hole B to adjust trolley width. Hole B is only used when installing the trolley on the rail.

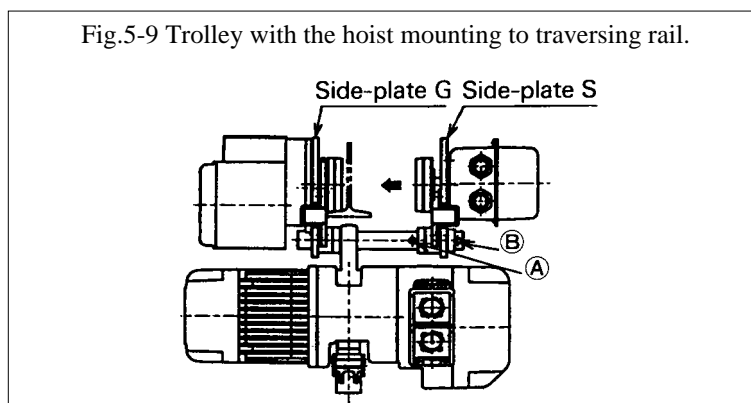

b) Installation of balance weight

The trolleys with capacity 1 tonne or less in dual speed, need a balance weight on them to keep stability on a rail flange of 75 mm in width.

As shown in Fig 5-10, place the balance weight over the suspension shaft and align with holes B and C. Fit the bolt into hole C and lock on the other end with the slotted nut and split pin.

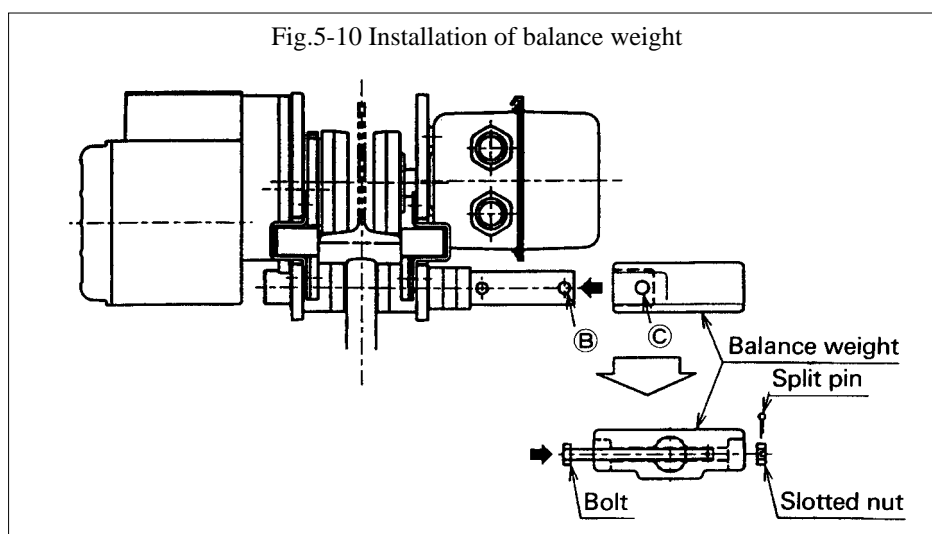

(c) Installation of stopper onto traversing rail

If using two or more trolleys on the same rail, separate them with end stops between every two trolleys. The distance between the end stops depends on the site requirements. Contact KITO or a KITO authorized dealer for help if required.

Make sure to install the end stops at both ends of the traversing rail.

5.3 Wiring and installation of power supply

⚠ DANGER

ALWAYS turn off the power source or breaker switch before wiring to prevent electric shock

Remark : For larger Capacity hoists (7.5t and larger), refer to the ERML-9806-MC manual.

⚠ CAUTION

Have all wiring performed by an authorized electrician or KITO dealer.

(1) Checking and changing wiring

Check or change wiring of the electric chain hoist and motorized trolley depending on the required voltage.
 Make wiring referring to the following figure. In case of the equipment for 575V, it is not necessary to change those connections.

Fig.5-11 1. Motor wiring

(1) Single speed type

Hoist : Capacity 125kg to 5t
 (exclude 500kg(L)(With Mechanical brake),
 1t(L), 1.5t, 2t(L), 3t(S))
 Trolley : Capacity 125kg to 5t

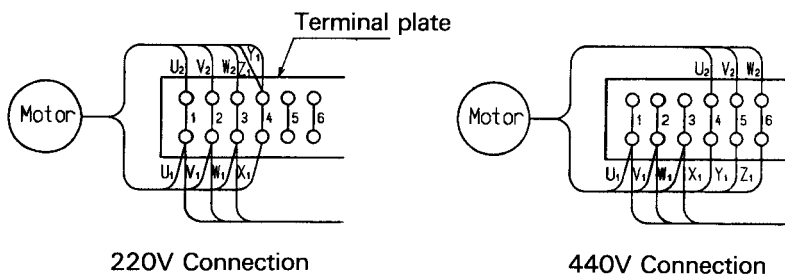

(2) Single speed type

Hoist : 500kg(L)(With Mechanical brake),
 1t(L), 1.5t, 2t(L), 3t(L), 3t(S)

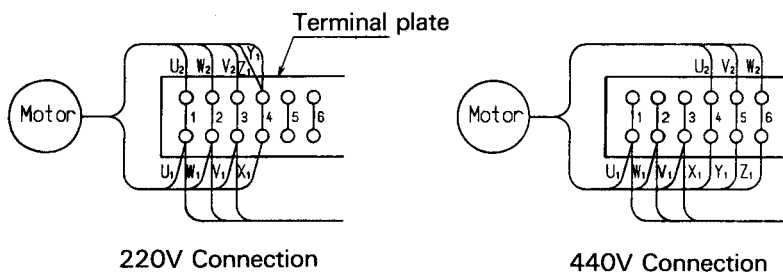

- (3) Dual speed type
 Hoist : Capacity 250kg to 5t
 (exclude 250kg(S)(With Friction clutch),
 250kg(H))
 Trolley : Capacity 125kg to 5t

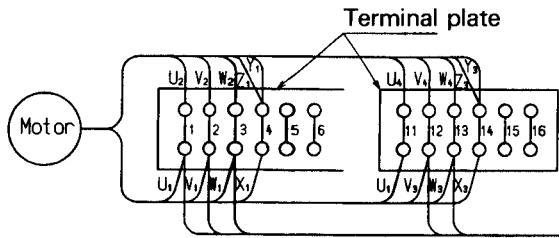

220V Connection

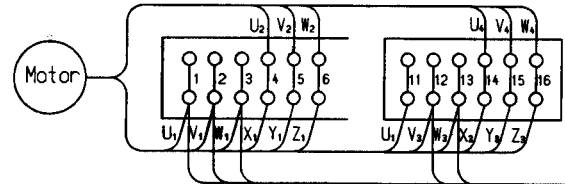

440V Connection

- (4) Dual speed type
 Hoist : 125kg, 250kg(S)(With Friction clutch),
 250kg(H)

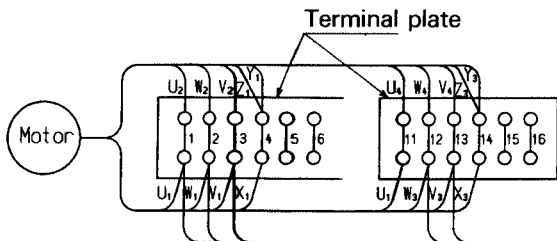

220V Connection

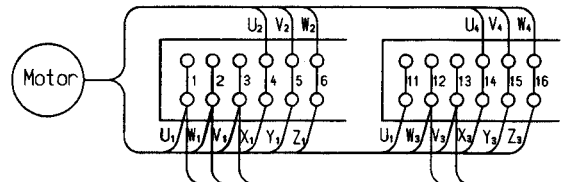

440V Connection

Fig.5-11 2. Transformer wiring

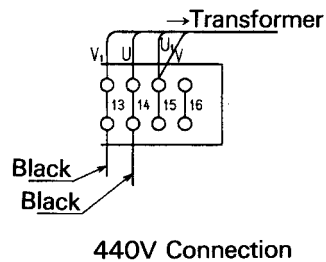
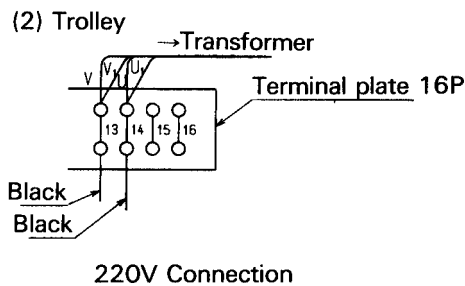
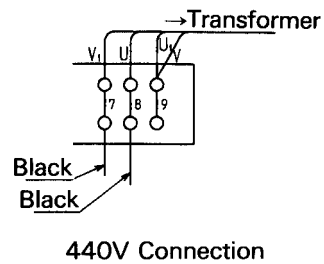
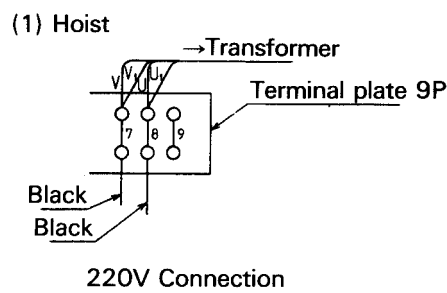

(2) Wiring of power supply cable

Remove the switch box cover and switch box packing.

Install firmly the cable holder to the switch box with screw.

Connect firmly red, black and blue lead wires of the cable to the terminal plate-16p referring to Fig.5-13. (Be sure to make each number of mark band of the lead wire consistently correspond to each number of the terminal plate)

The green and yellow stripped lead wire is the ground wire. Connect the wire to the ground mark of the plate firmly.

After checking if there is no mistake in wiring work, install the switch box packing and the cover of switch box.

Note : Refer to the wiring diagram attached on the inside of controller cover of the hoist and or the switch box cover of the motorized trolley if necessary.

Fig.5-13 Wiring of power supply cable
(motorized trolley type electric chain hoist)

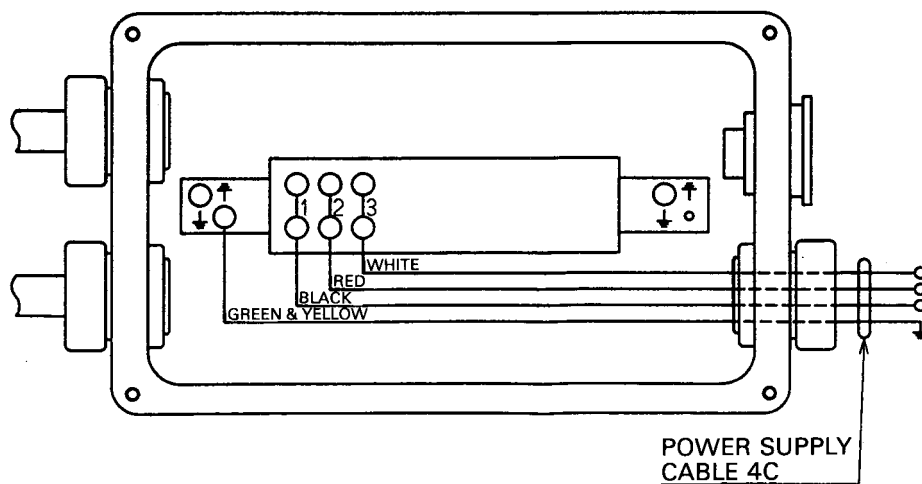

(3) Installation of power supply cable.

Install power supply cable as the following procedure.

(a) Providing messenger wire

Provide messenger wire (3 to 6 mm diameter steel cable) along the beam, make the power supply cable run with the cable hangers through the messenger wire so that it would not be twisted.

(b) Setting messenger wire to the position of wire guide (Fig 5-14)

Fit cable support to the cable support arm.

When the curved beam is used, the messenger wire can not be attached to the beam. For this case, a special T type cable hanger for the curved beam should be ordered as an optional item.

The number of special T type cable hanger and the intervals of installation depend on the position and the radius of the curve.

Therefore consult KITO dealer for this matter.

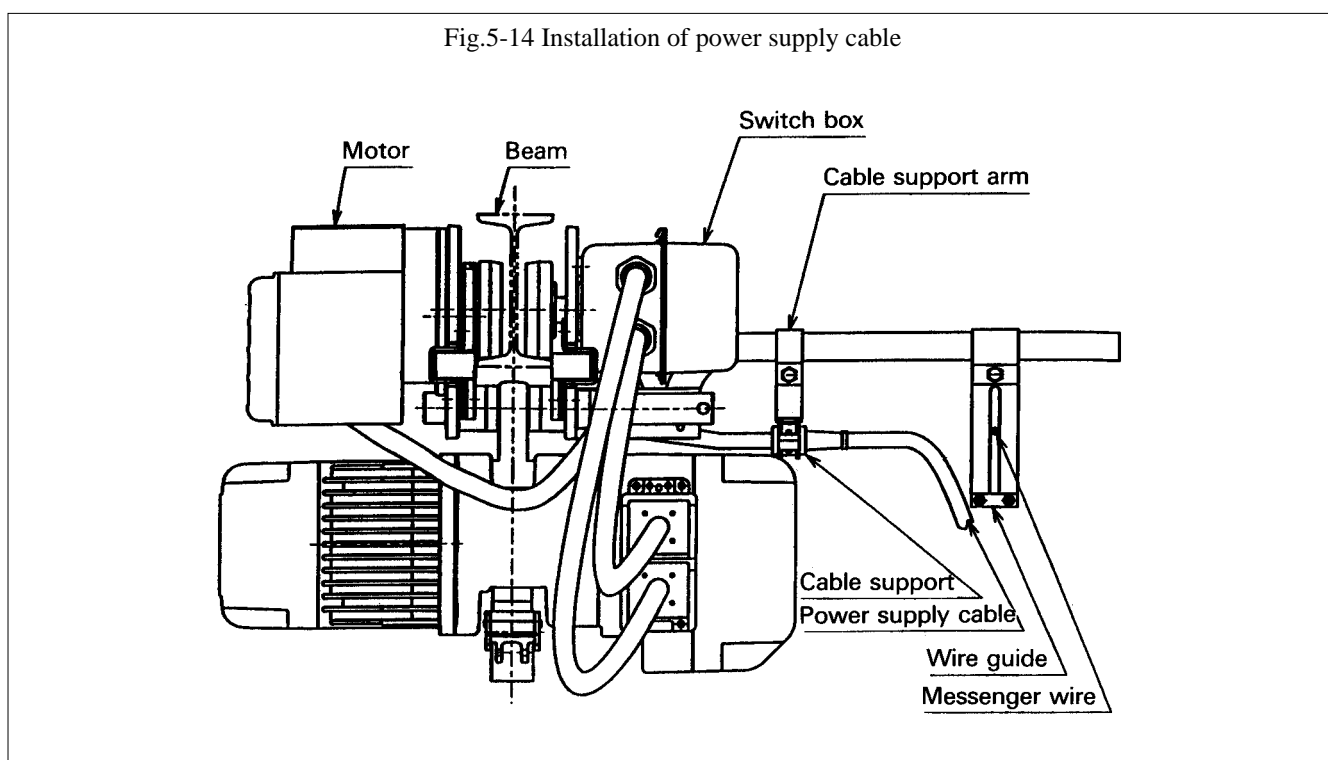

Consult KITO dealer in case the electrical power supply is by means of any other method

(4) Connection of power supply cable to electric power source

(a) Connection to electric power switch

Three wires of red, black and blue of the power supply cable should be connected to the electric power switch. Sometimes it may be required to change the connections but lead wires should be firmly connected again to the power source for better function. (See Fig. 5-15)

Fig.5-15 Connection of power supply cable to electric power source

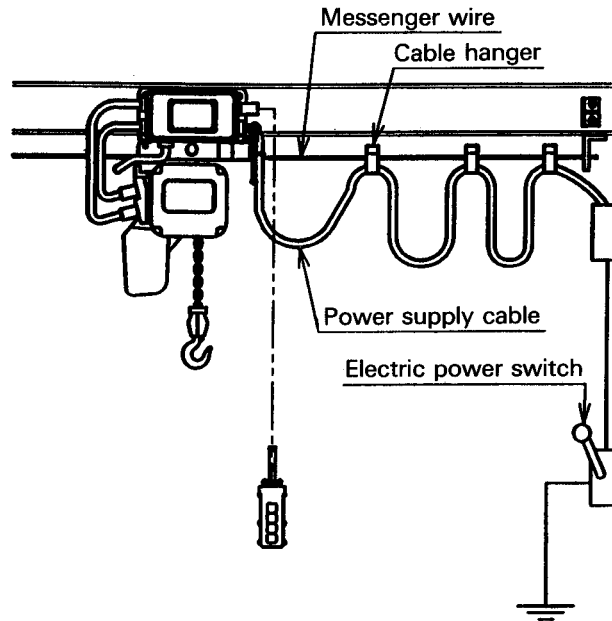

(b) Fuse and breaker capacity

The fuse and breaker should be chosen for each rated capacity shown in the following table for safety.

Table 5-3 Capacity of fuse and circuit breaker

ER, ERP, ERG (single speed type)

Capacity (kg or t)	Motor output		Minimum size of wiring (mm ²)		Rating						Ordinary graduation of ammeter			Minimum size of ground wire (mm ²)	
	Lift				Fuse(A)			Breaker(A)							
	kW	HP	220/ 440V	575V	220 v	440 v	575 v	220 v	440 v	575 v	220 v	440 v	575 v		
125(H),250(S) 500(L)	0.56	0.75	AWG 14	AWG 14	10	5	5	15	5	5	5	5	5	AWG14	
250(H),500(S) 1(L)	0.9	1.2			10	5	5	10	5	5	10	5	5		
1(M)	1.4	1.9			15	10	5	15	10	5	15	10	5		
1(S),1.5(S),2(L)	1.8	2.4			2(S),2.5(S), 3(L),5(L)	3.5	4.7	30	15	10	30	15	10		20
2(M), 3(C)	2.8	3.8	AWG 12	AWG 12	40	20	15	40	20	15	30	15	10		
3(S)	4.6	6.1			40	20	15	40	20	15	30	15	10		

ER, ERP, ERG (dual speed type)

Capacity (kg or t)	Motor output		Minimum size of wiring (mm ²)		Rating						Ordinary graduation of ammeter			Minimum size of ground wire (mm ²)
	Lift				Fuse(A)			Breaker(A)						
	kW	HP	220/ 440V	575V	220 v	440 v	575 v	220 v	440 v	575 v	220 v	440 v	575 v	
125(H),250(S) 500(L)	0.45 / 0.15	0.6 / 0.2	AWG 14	AWG 14	10	5	5	10	5	5	5	5	5	AWG14
250(H),500(S) 1(L)	0.9 / 0.3	1.2 / 0.4			10	5	5	10	5	5	10	5	5	
1(S),1.5(S),2(L)	1.8 / 0.6	2.4 / 0.8			15	10	5	15	10	5	10	5	5	
2(S),2.5(S), 3(L),5(L)	3.5 / 1.2	4.7 / 1.6	AWG 12	AWG 14	30	15	15	30	15	15	20	10	10	
3(S)	4.6 / 1.5	6.1 / 2.0			40	20	20	40	20	20	30	15	10	

ERM (single speed type)

Capacity (kg or t)	Motor output				Minimum size of wiring (mm ²)		Rating						Ordinary graduation of ammeter			Minimum size of ground wire (mm ²)
	Lift		Travel				Fuse(A)			Breaker(A)						
	kW	HP	kW	HP	220/ 440V	575V	220 v	440 v	575 v	220 v	440 v	575 v	220 v	440 v	575 v	
125(H),250(S) 500(L)	0.56	0.75	0.4	0.53	AWG 12	AWG 14	10	5	5	10	5	5	10	5	5	AWG14
250(H),500(S) 1(L)	0.9	1.2					15	10	5	15	10	5	10	5	5	
1(M)	1.4	1.9					20	10	10	20	10	10	15	10	10	
1(S),1.5(S),2(L)	1.8	2.4					30	15	15	30	15	15	30	10	10	
2(M), 3(C)	2.8	3.8					30	15	15	30	15	15	30	15	15	
2(S),2.5(S), 3(L)	3.5	4.7					40	20	15	40	20	15	30	15	15	
5(L)	3.5	4.7					0.75	1	30	15	15	30	15	15	30	
3(S)	4.6	6.1	0.4	0.53	40	20	15	40	20	15	30	15	15			

ERM (dual speed type)

Capacity (kg or t)	Motor output				Minimum size of wiring (mm ²)		Rating						Ordinary graduation of ammeter			Minimum size of ground wire (mm ²)		
	Lift		Travel				Fuse(A)			Breaker(A)								
	kW	HP	kW	HP	220/ 440V	575V	220 v	440 v	575 v	220 v	440 v	575 v	220 v	440 v	575 v			
125(H),250(S) 500(L)	0.45 / 0.15	0.6 / 0.2	0.32 / 0.08	0.43 / 0.11	AWG 12	AWG 14	10	5	5	10	5	5	10	5	5			
250(H),500(S) 1(L)	0.9 / 0.3	1.2 / 0.4					15	10	5	15	10	5	10	5	10	5	5	
1(S),1.5(S),2(L)	1.8 / 0.6	2.4 / 0.8					20	10	10	20	10	10	15	10	10	15	10	10
2(S)	3.5 / 1.2	4.7 / 1.6					30	15	15	30	15	15	30	15	15	30	10	10
2.5(S),3(L),5(L)	3.5 / 1.2	4.7 / 1.6					0.64 / 0.16	0.85 / 0.21	30	15	15	30	15	15	30	15	15	15
3(S)	4.6 / 1.5	6.1 / 2.0					40	20	20	40	20	20	30	15	15	30	15	15

(c) Ground wire

The green and yellow stripped wire is the ground wire, which should always be connected to a suitable ground. Unless the wire is grounded, operator may sometimes feel a shock when touching any part of the hoist or chain.

NEVER paint the trolley running surface of the beam.

5.4 Trial run

(1) Before proceeding

Review the previous sections of the manual to be sure that each step was completed properly and that all parts are attached securely.

For example :

- (a) Whether the electric chain hoist is properly installed to the trolley. (See, Fig.6-7)
- (b) Whether the stopper of the trolley on the beam is correctly positioned.
- (c) Whether the bolts, nuts, and split pins are all sufficiently fastened.
- (d) Whether the push button cord wire supports the force if the pendant is pulled.
- (e) Whether the cable support is firmly installed to the cable support arm.

⚠ DANGER

ALWAYS turn off the power source or breaker switch before performing any mechanical or electrical maintenance on the equipment.

(2) Check lifting

Connect the main switch supplying power to the equipment. Push the  push button switch and if the hook does not move in the correct direction, the power supply is phased incorrectly. In this case, turn off the power source or breaker switch and then reverse any two of the three power supply wires at the hoist's power source. The hook will then move in accordance with the directions of the push button.

(3) Check traversing

Verify that the controls agree with trolley direction. Make sure the trolley runs smoothly and attach the E/W or N/S direction labels to the buttons.



(4) Check limit switch function

Refer to the name plate AB or AC, written "Upper Limit" or "Upper/Lower Limit", which is attached on the hoist to make sure which types limit switch is equipped with the hoist. No name plate means no limit switch.





(a) Upper limit switch

Hold down the  button until the bottom hook activates the upper limit switch, and make sure if the hoist stops at the upper limit position.

(b) Upper and lower limit switch





Hold down the  button until the bottom hook activates the limit switch, and make sure if the hoist stops at the upper limit position. Then hold down the  button until the bottom hook reaches the lower limit position to activate the limit switch, and make sure if the hoist stops. In both cases, make sure that the chain spring is compressed with enough clearance.

(5) Check the lift and lower brake functions

Lift up a suitable load. Push the  or  and  or  buttons on the push button switch to raise or lower the hook a few times. Make certain the brake stops the motor immediately when releasing the buttons.

(6) Check the optional emergency stop device function (as option)

This device is an option for the electric chain hoist, a standard for electric chain hoist with motorized trolley.

While holding down either the  ,  ,  or  button on the push button switch, push the emergency stop button. Check that the hook stops when the emergency stop button is pushed. Also, check the hoist does not move in response to the push button switch. Finally, release the emergency stop button which pops out by turning it to the right, and then operation can be resumed thereafter. If the equipment fails to pass any of the above checks, check the wiring and automatic locking function of the emergency stop device.

6. OPERATION

After pre-usage preparation and checks are completed, the hoist will be ready for normal operation.

6.1 Intended purpose of hoist operation

The hoist is designed for vertically lifting, lowering and horizontally carrying loads by means of switching the pendant push button under normal atmospheric conditions of the workplace.

Since dealing with heavy loads may involve unexpected danger, all the "Safety instructions" (Refer to 3.2.) must be followed.

6.2 Safe working environment

⚠ WARNING

The operator must be aware of the following points while using the hoist.

- (1) The operator must have a clear and unobstructed view of the entire travel area before operating the hoist. When not possible, a second or more persons must serve as scouts in the nearby area.
- (2) The operator must check the entire work place is safe and secure before operating the hoist.
- (3) The operator must make sure to prevent his hands or other parts of his body from being caught in the moving hoist.





6.3 Electric chain hoist

KITO electric chain hoists ER series come in single speed and dual speed models.

For an explanation on how to operate the hoists, refer to Table 6-1.

Table 6-1 Operation of hoist

Electric chain hoist	Single speed		
	Dual speed		
Push button switch			

Operation method	lifting or lowering	The push button is a single step push type. Push and hold down the  button to lift and the  button to lower the load. Release the button to stop.	The push button is a dual step type. The first step is for low speed and the second step for high speed. Push and hold down the  button to lift and the  button to lower the load. Release the button to stop.
	Emergency stop device (option)	This button is used to stop lifting or lowering in an emergency situation. It is a red, mushroom type button, located in the uppermost position on the push button switch box. When pushed, power to the equipment is shut off and the button locks automatically. Turn it to the right to release the lock.	

6.4 Electric chain hoist with motorized trolley

6.4.1 Operation

KITO electric chain hoist ER series and motorized trolley MR series both come in single speed and dual speed models.

For an explanation on how to operate the hoist, refer to Table 6-2.

Table 6-2 Operation of hoist and trolley

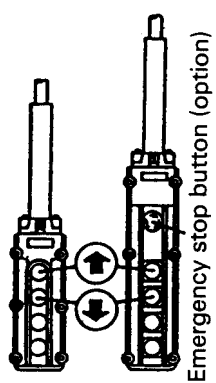
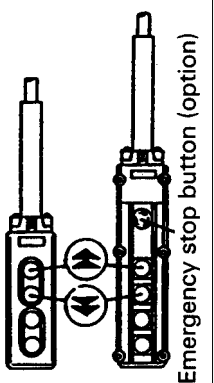
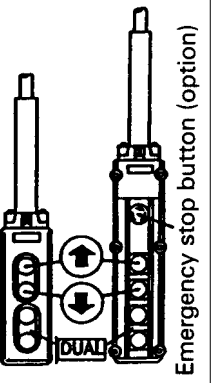
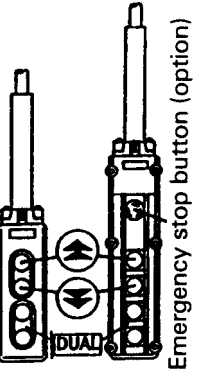
Electric chain hoist	Single speed		-		-
	Dual speed			-	
Motorized trolley	Single speed			-	-
	Dual speed	-	-		
Push button switch					

Operation method	lifting or lowering	Refer to Table 6-1.	
	Traversing	The push button switch is a single step push type. The hoist will move in the direction of the EW or NS marks when the lower two buttons are pushed. Release the button to stop.	The push button switch is a dual step push type. The first step is for low speed and the second step for high speed. The hoist will move in the direction of the EW or NS marks when either of the lower two buttons is pushed. Release the button to stop.
	Emergency stop device	Refer to Table 6-1.	

6.4.2 Precautions in usage

The more the load swings, the more difficult and dangerous it is to operate the trolley. Use the method undermentioned to minimize the load swing. Refer to Fig.6-1.

- (1) Push the button of trolley traversing.
- (2) Immediately after the load moves to the position shown in (b), release the button till the load comes to (c).
- (3) When the load moves to the position shown in (c), push the same button again.

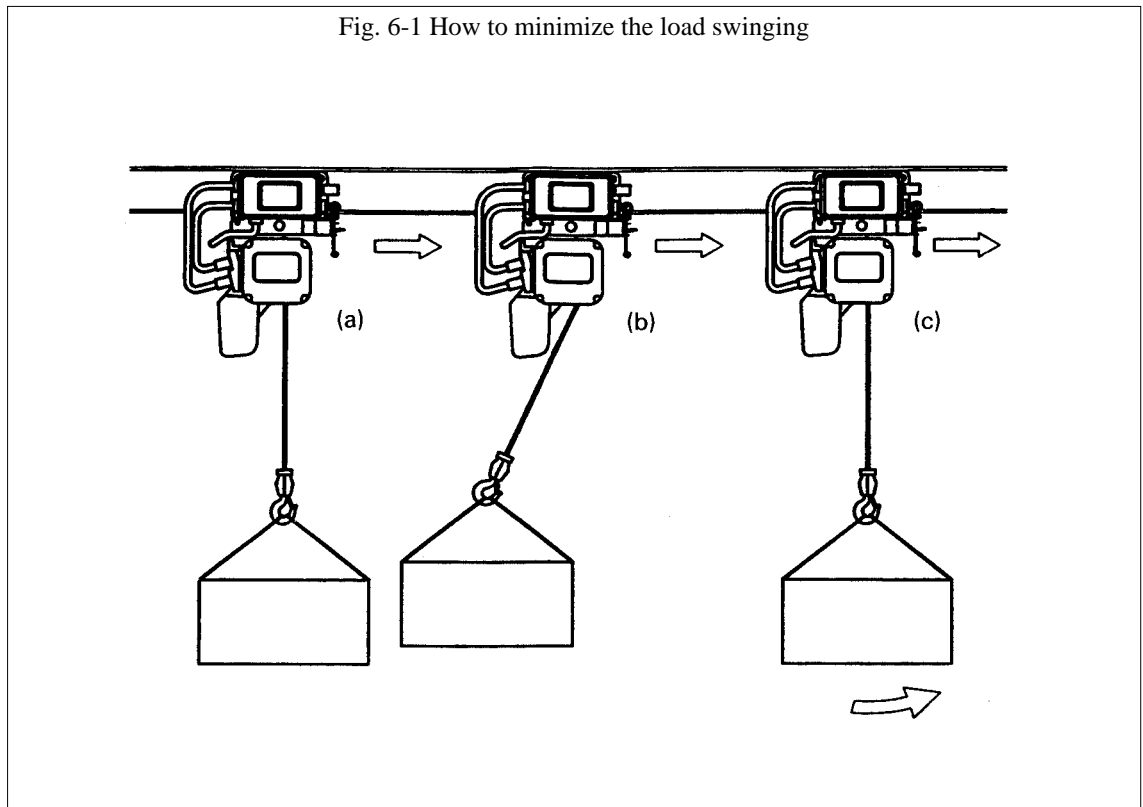

7. MAINTENANCE

⚠ WARNING

NEVER perform maintenance on the hoist while it is supporting a load. However, this does not apply when checking the brake, friction clutch or limit switch in the periodic inspection.

Before performing maintenance, attach tags to the power source and the push button switch reading;

"DANGER" **NEVER OPERATE EQUIPMENT BEING REPAIRED!**

ALWAYS use the hoist manufacturer's genuine parts when repairing a hoist. Only allow qualified service personnel to perform maintenance.

ALWAYS lock-out power source before conducting maintenance. However, this does not apply when checking push button switch operation and power supply voltage.

After performing any maintenance on the hoist, **ALWAYS** test to its Capacity before returning into service.

ALWAYS make sure to prevent hands or other parts of your body from being caught in the moving parts.

7.1 Lubrication

7.1.1 Gear lubrication

Change the gear oil, referring to the rate of loading and the operating hours in the following table. At least, however, change it every 5 years even though the operating hour doesn't reach the specified hour.

Rate of Loading		Operating Hours		
		120 hrs	240 hrs	360 hrs
Light	When normally working with an approximate 1/3 of the rated load and rarely with the rated load.			
Medium	When normally working with an approximate 1/3 to 2/3 of the rated load and sometimes with the rated load.			
Heavy	When normally working with an approximate 2/3 of the rated load and often with the rated load.			
Very heavy	When normally working with the rated load or near the rated load.			

To change the gear oil, remove both the oil plug and the drain plug and drain the old gear oil completely before refilling the new specified one.

⚠ WARNING

Using oils other than the specified standard or similar grade oils may prevent the friction clutch from working properly and may cause the hoist to drop the load.

Notice : Dispose old oil in accordance with local regulations.

7.1.2 Load chain lubrication

Refer to ' 5.1(3) Lubricating the load chain. '

⚠ WARNING

ALWAYS lubricate load chain once a week, or more frequently, depending on severity of service.

ALWAYS lubricate more frequently than normal in corrosive environment (In salt water, sea air and/or acid or other corrosive compounds)

7.2 Chain replacement

Observe the procedure below when replacing the chain referring to Fig.7-1. For single and double fall chains.

Refer to 7-2-1 and 7-2-2 respectively.

7.2.1 Single fall chain

- (1) Remove the stopper from the no load side.
- (2) Hook the C-link to the end link.
- (3) Hook the end link of the new chain to the C-link.
- (4) Operate the hoist to lower the chain.
- (5) Stop to lower the chain when a sufficient amount of new chain is accumulated on the load side.
- (6) Attach the chain spring or cushion rubber and bottom hook from the old chain to the end of the new chain on the load side.
- (7) Attach the chain spring or cushion rubber and stopper from the old chain to the correct link on the new chain on the no load side.

7.2.2 Double fall chain

- (1) Remove the stopper from the no load side.
- (2) Hook the C-link to the end link.
- (3) Hook the end link of the new chain to the C-link.
- (4) Operate the hoist to lower the chain.
- (5) Stop lowering the chain when a sufficient amount of new chain is accumulated on the load side.
- (6) Feed the end link on the load side of the new chain through the idle sheave completely.
- (7) When connecting the end link to the connection yoke by a chain pin, make sure that the chain is not twisted throughout the whole links.
- (8) Attach the chain spring or cushion rubber and stopper from the old chain to the correct link on the new chain on the no load side.

Fig. 7-1 Chain replacement

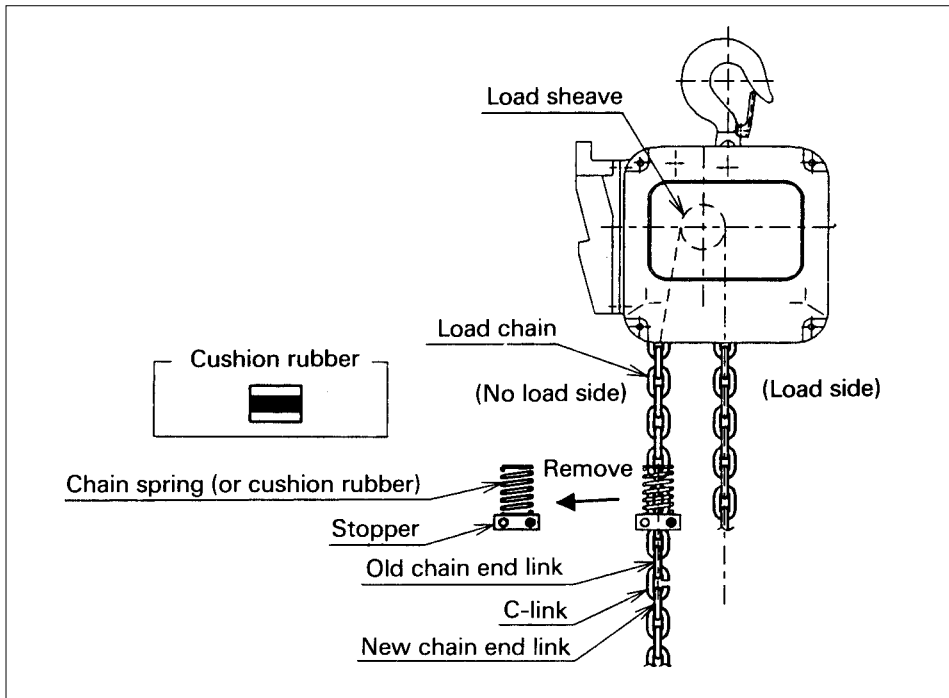

7.3 inspection

7.3.1 Inspection classification

- (1) Initial inspection : Prior to initial use, all new, altered or modified hoists shall be inspected by a designated personnel to ensure compliance with the applicable provisions of this manual.
- (2) Inspection procedure for hoists in regular service is divided into two general classifications based upon the intervals at which inspection should be performed. The intervals in turn are dependent upon the nature of the critical components of the hoist and the degree of their exposure to wear, deterioration or malfunction. The two general classifications are herein designated as daily and periodic with respective intervals between inspections as defined below.
 - (a) Daily inspection : visual examinations by the operator or other designated personnel
 - (b) Periodic inspection : visual inspection by a designated personnel
 - 1) normal service; yearly
 - 2) heavy service; semiannually
 - 3) strict service; quarterly
 - 4) special or infrequent service; as recommended by a qualified personnel before the first such occurrence and as directed by the qualified personnel for any subsequent occurrences

7.3.2 Daily inspection

(see table)

Items such as those listed in the recommended "Daily inspection" in the section 7.3.6 should be inspected for defects and damages. This includes observations during operation for any defects or damages that might appear between "Periodic inspection". A designated personnel shall determine whether any defects or damages constitute a hazard or will require more detailed inspection.

7.3.3 Periodic inspection

(see table)

Complete inspections of the hoist shall be performed as recommended periodic inspection. These inspections may be performed with the hoist in its normal location and do not require the entire hoist to be dismantled. Covers and other components should be opened or removed for these inspection.

The recommended periodic inspection in the section 7.3.6 shall be examined by a designated personnel to determine whether they constitute a hazard or whether complete disassembly is necessary. These inspections shall include the requirements of daily inspection.

7.3.4 Occasionally used hoist

- (1) A hoist which is idle for a period of one month or more but less than one year shall be given an inspection conforming to the requirements of section 7.3.2 before it is placed in service.
- (2) A hoist which is idle for a period of one year shall be given an inspection conforming to the requirements of section 7.3.3 before it is placed into service.

7.3.5 Inspection record



Dated inspection reports and records should be maintained at time intervals specified in section 7.3.1 (2)(b) and such records are stored where they are available to authorized personnel.



7.3.6 Inspection procedure

Remark : For larger Capacity hoists (for ER : 7.5t and larger, ERM : 7.5t and larger), refer to "Inspection procedure" in 7.3.6 and instruction manual ERML-9806-MC.

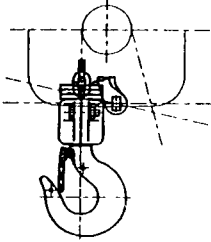
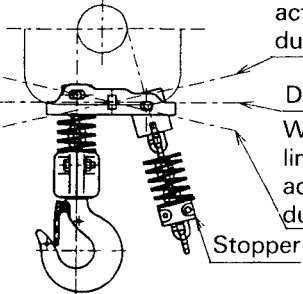
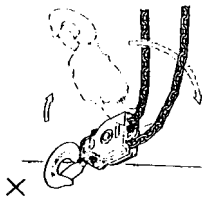
(1) Daily inspection

Class	Item	Inspection method	Discard limit/criteria	Remedy
Common for electric chain hoist and trolley	1. Push button (1) Emergency stop	Press the emergency stop button while the hoist is under no load condition.	The emergency stop function operates and the suspended state remains. After turning the emergency stop button to the right, the hook can be lifted or lowered, or the trolley can be traversed.	If equipment fails to stop in response to the emergency stop button or if the suspended state cannot remain, replace the emergency stop device. If the button cannot be reset, replace the device.
	(2) Cracked housing	Check visually.	No cracks.	Replace with a new case.
Electric chain hoist	1. Push button (1) Function	Operate the push buttons under no load condition.	Bottom hook can be lifted and lowered.	If the bottom hook won't move, check power source or see if the cord is disconnected.
	2. Brake (1) Function	Lift and lower 2 or 3 times under no load condition.	When the push button is released, the brake operates and the motor stops immediately.	If the motor does not stop immediately, ask the service personnel to inspect and repair it.

Class	Item	Inspection method	Discard limit/criteria	Remedy
Electric chain hoist	3. Limit switch (overwind limiting device)	Refer to the name plate AB or AC (written "Upper Limit" or "Upper/Lower Limit") which is attached on the hoist to make sure which types limit switch are equipped with the hoist. No name plate means no limit switch.		
	(1) Upper limit switch function	Operate the hoist under no load condition until bottom hook reaches the limit lever.	When the bottom hook reaches the limit lever, the motor stops automatically. (Limit lever positions during motor stoppage and operation are shown below.)  When the hook pushes up the limit lever, the limit switch is activated to stop the motor during lifting.	If there are abnormalities, ask the service personnel to inspect and repair them.
	(2) Upper and lower limit switch function	Operate the hoist under no load condition until bottom hook or stopper reaches the limit lever.	When the bottom hook or the stopper reaches the limit lever, the motor stops automatically. (Limit lever positions during motor stoppage and operation are shown below.)  When the stopper pushes up the limit lever, the limit switch is activated to stop the motor during lowering. During stoppage or operation When the hook pushes up the limit lever, the limit switch is activated to stop the motor during lifting. Stopper	If there are abnormalities, ask the service personnel to inspect and repair them.
	4. Load chain (1) Appearance	Check visually for greasing and twisting.	Load chain is well lubricated.  X  O Load chain is not twisted or capsized.	If chain is dry, apply the specified lubricant in the section ' 5.1(3). ' If chain is twisted, untwist it and restore it to normal chain condition.

Class	Item	Inspection method	Discard limit/criteria	Remedy
Electric chain hoist	5. Hook			
	(1) Bottom hook deformation	Check visually	Shape has not deformed from what it was at time of purchase.	Replace the hook with a new one if deformed.
	(2) Hook latch operation	Move with hand or check visually.	Free of deformation and damage. Operates normally.	Replace the hook latch with a new one if deformed or malfunctioning.
	6. Chain spring and cushion rubber			
(1) Chain spring deformation	Check visually.	NEVER use spring if it is deformed as illustrated or if it stays compressed and won't open.	 Replace chain spring with a new one if deformed.	
(2) Cushion rubber deformation	Check visually	NEVER use cushion rubber if it is deformed as illustrated.	 Replace cushion rubber with a new one if deformed.	
Trolley	1. Push button			
	(1) Function	Operate the push buttons under no load condition.	Traverses smoothly.	If trolley does not move, check power source or see if the cord is disconnected.
	2. Traversing unit			
(1) Motor brake operation	Run and stop 2 or 3 times under no load condition.	When the brake is used, the motor stops immediately.	If there are any abnormalities, ask the service personnel to inspect and repair them.	
(2) Function		The trolley runs smoothly.		
	3. Side plate			
	(1) Deformation	Check visually	NEVER use if it seems to be deformed (as revealed by visual check).	Replace the side plate with a new one if deformed.

(2) Periodic inspection

Class	Item	Inspection method	Discard limit/criteria	Remedy																																																
Electric chain hoist & Trolley	1. Push button (1) Operation	Push buttons in turn.	Movement is smooth without extreme play and interference.	Inspect and repair it if operation is abnormal.																																																
	(2) Emergency stop function (3) Loose wiring joint	Stop and reset the equipment 2 or 3 times using the emergency stop button. Check visually.	The button should operate smoothly and be void of extreme play and interference. Screws are not loose or missing.	Inspect and repair it if operation is abnormal. Tighten further if it is loosened.																																																
Hoist & Trolley	2. Main body and traversing unit (1) Cable or cord joint damage	Check visually.	Free of noticeable damage.	Repair cables / cords or replace them with new ones.																																																
	3. Power supply, ground, insulation, control circuit (1) Control circuit fuse installation and capacity	Remove the controller cover and check visually fuse installation. Check fuse capacity.	The fuse should be securely fit in the prescribed location. As indicated on the below table.	Fit in the prescribed location. Install a fuse of the proper capacity.																																																
		<table border="1"> <thead> <tr> <th rowspan="3">Capacity (kg or t)</th> <th rowspan="3">Location (inside)</th> <th colspan="4">Fuse capacity (Ampere)</th> </tr> <tr> <th colspan="2">ER</th> <th colspan="2">ERM</th> </tr> <tr> <th>Single speed</th> <th>Dual speed</th> <th>Single speed</th> <th>Dual speed</th> </tr> </thead> <tbody> <tr> <td rowspan="2">125kg to 1.5 ,2(L), 2(M), 3(C)</td> <td>switch box</td> <td>.....</td> <td>.....</td> <td>2</td> <td>2</td> </tr> <tr> <td>controller cover</td> <td>2</td> <td>2</td> <td>2</td> <td>2</td> </tr> <tr> <td rowspan="2">2(S), 2.5, 3(L), 5</td> <td>switch box</td> <td>.....</td> <td>.....</td> <td>2</td> <td>2</td> </tr> <tr> <td>controller cover</td> <td>3</td> <td>3</td> <td>3</td> <td>3</td> </tr> <tr> <td rowspan="2">3(S)</td> <td>switch box</td> <td>.....</td> <td>.....</td> <td>2</td> <td>2</td> </tr> <tr> <td>controller cover</td> <td>3</td> <td>5</td> <td>3</td> <td>5</td> </tr> </tbody> </table>				Capacity (kg or t)	Location (inside)	Fuse capacity (Ampere)				ER		ERM		Single speed	Dual speed	Single speed	Dual speed	125kg to 1.5 ,2(L), 2(M), 3(C)	switch box	2	2	controller cover	2	2	2	2	2(S), 2.5, 3(L), 5	switch box	2	2	controller cover	3	3	3	3	3(S)	switch box	2	2	controller cover	3	5	3	5
Capacity (kg or t)	Location (inside)	Fuse capacity (Ampere)																																																		
		ER		ERM																																																
		Single speed	Dual speed	Single speed	Dual speed																																															
125kg to 1.5 ,2(L), 2(M), 3(C)	switch box	2	2																																															
	controller cover	2	2	2	2																																															
2(S), 2.5, 3(L), 5	switch box	2	2																																															
	controller cover	3	3	3	3																																															
3(S)	switch box	2	2																																															
	controller cover	3	5	3	5																																															

Class	Item	Inspection method	Discard limit/criteria	Remedy
Hoist & Trolley	(2) Grounding	Check grounded point.	Grounding resistance should be 100 Ohm or less. For the collector type, the trolley-running surface of the beam is free of insulating materials, such as paint. Also, the beam is perfectly grounded.	Ground in compliance with local laws and regulations. Remove insulating materials.
	(3) Voltage measurement of the connection box at receiving point	Measure with a voltmeter.	Voltage is within $\pm 10\%$ of rated voltage during rated running (of the electric chain hoist).	Check that both the cable and power source capacity are appropriate.
	(4) Measurement of insulation resistance	Measure charged and uncharged parts with an insulation resistance tester.	Insulation resistance is 5 M.Ohm or more.	Investigate cause and replace defective parts.
	1. Main body			
	(1) Casing damage	Check visually.	Body is free of flaws and cracks.	Replace casing with a new one if damaged or cracked.
	(2) Abnormal sound during operation	Lift and lower by suspending a light load.	Motor or main body interior does not generate vibration, noise or irregular sounds.	If abnormal sounds are heard, ask the service personnel to inspect.

Class	Item	Inspection method	Discard limit/criteria	Remedy
Hoist & Trolley	(3) Quantity of gear oil and contamination	Check visually.	Change oil regularly in keeping with work frequency.	Provide oil if the quantity is insufficient. If oil is badly contaminated, replace it with new oil. Notice : Dispose old oil in accordance with local regulations.
	(4) Controller cover damage	Check visually.	Free of deformation and cracks.	If the deformation exists, replace the controller cover with a new one.
	(5) Name plate damage	Check visually.	WLL is readable.	Replace the name plate with a new one if illegible.
	(6) Loose or missing screws	Check visually.	Screws are not loose or missing.	Tighten or replace.
2. Brake	(1) Function	Suspend the rated load. Lift, lower and stop it.	When switched off in the middle of lowering, the chain stops within about two links and less than 1% of lifting speed (m/min.) after turning off the hoist.	If the stopping distance is too large, ask the service personnel to inspect and repair it.

Class	Item	Inspection method	Discard limit/criteria	Remedy
Hoist & Trolley	3. Friction clutch (1) Function	Lift up a grounded load. Press the  button and check from the outside that the motor rotates. After confirming the function of Friction Clutch, don't keep slipping longer than 5 seconds. Lift up the rated load.	The motor should rotate. The rated load should be lifted up.	If the motor fails to rotate, ask the service personnel to inspect. Never adjust the friction clutch and replace the friction clutch as needed. If not, ask the service personnel to inspect. Never adjust the friction clutch and replace the friction clutch as needed.
	4. Limit switch (overwind limiting device)	Refer to the name plate AB or AC (written "Upper Limit" or "Upper/Lower Limit") which is attached on the hoist to determine which types limit switch are equipped with the hoist. No name plate means no limit switch.		
	(1) Limit lever and cross guide damage	Check visually.	The limit lever and cross guide are free of damage and deformation.	Replace with new ones if damaged or deformed.
	(2) Stopper damage	Check visually.	The stopper, and cushion rubber or chain springs at chain ends are not deformed or detached.	Replace with new ones if damaged or deformed.
(3) Function	Suspend the rated load and operate the limit switch until the bottom hook or stopper reaches the limit lever.	The chain spring should give sufficient allowance of chain after the motor has stopped. (For the position of the limit lever, refer to item 3 in the figure entitled "Daily inspection".)	If there are any abnormalities, ask the service personnel to inspect and repair them.	

Class	Item	Inspection method	Discard limit/criteria	Remedy																																												
Hoist & Trolley	5. Load chain (1) Abrasion	To measure pitch with slide calipers: Measure at the point that is most frequently engaged with load sheave.	Dimension (P) or (d) shall not exceed the limits presented in the table below.	If limit exceeds, ALWAYS ask the service personnel to run an inspection.																																												
			<p>The diagram shows a side view of a chain link. A horizontal dimension line labeled 'P' spans the distance between the centers of two adjacent links. A vertical dimension line labeled 'd' indicates the diameter of the link's body.</p>																																													
			<table border="1"> <thead> <tr> <th rowspan="2">Chain size (d)</th> <th rowspan="2">Capacity (kg or t)</th> <th rowspan="2">Number of measured links</th> <th colspan="2">Pitch of measured links : P</th> <th rowspan="2">Discard limit of (d)</th> </tr> <tr> <th>Standard</th> <th>Limit</th> </tr> </thead> <tbody> <tr> <td>5.0</td> <td>125(H) 250(S)</td> <td>5</td> <td>75.5</td> <td>77.7</td> <td>4.5</td> </tr> <tr> <td>6.3</td> <td>250(H) 500(L), 500(S)</td> <td>5</td> <td>95.5</td> <td>98.3</td> <td>5.7</td> </tr> <tr> <td>8.0</td> <td>1(L), 1(M), 1(S)</td> <td>5</td> <td>121.0</td> <td>124.6</td> <td>7.2</td> </tr> <tr> <td>10.0</td> <td>1.5, 2(L), 2(M), 2(S), 3(C)</td> <td>5</td> <td>151.0</td> <td>155.5</td> <td>9.0</td> </tr> <tr> <td>11.2</td> <td>2.5(S), 5(L)</td> <td>3</td> <td>102.6</td> <td>105.6</td> <td>10.1</td> </tr> <tr> <td>12.5</td> <td>3(L), 3(S)</td> <td>3</td> <td>114.6</td> <td>118.0</td> <td>11.3</td> </tr> </tbody> </table>	Chain size (d)	Capacity (kg or t)	Number of measured links	Pitch of measured links : P		Discard limit of (d)	Standard	Limit	5.0	125(H) 250(S)	5	75.5	77.7	4.5	6.3	250(H) 500(L), 500(S)	5	95.5	98.3	5.7	8.0	1(L), 1(M), 1(S)	5	121.0	124.6	7.2	10.0	1.5, 2(L), 2(M), 2(S), 3(C)	5	151.0	155.5	9.0	11.2	2.5(S), 5(L)	3	102.6	105.6	10.1	12.5	3(L), 3(S)	3	114.6	118.0	11.3	
Chain size (d)	Capacity (kg or t)	Number of measured links	Pitch of measured links : P				Discard limit of (d)																																									
			Standard	Limit																																												
5.0	125(H) 250(S)	5	75.5	77.7	4.5																																											
6.3	250(H) 500(L), 500(S)	5	95.5	98.3	5.7																																											
8.0	1(L), 1(M), 1(S)	5	121.0	124.6	7.2																																											
10.0	1.5, 2(L), 2(M), 2(S), 3(C)	5	151.0	155.5	9.0																																											
11.2	2.5(S), 5(L)	3	102.6	105.6	10.1																																											
12.5	3(L), 3(S)	3	114.6	118.0	11.3																																											
	6. Accessories (1) Hook deformation / twist of hook opening	Measure dimension "a" at time of purchase with slide calipers. Check visually.	No deformation from original shape (at time of purchase) Twist shall not be large enough to detect visually.	Replace with new hook if deformed. Replace with new hook if twisted.																																												

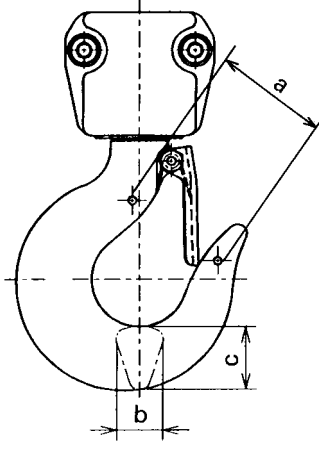
Class	Item	Inspection method	Discard limit/criteria	Remedy																																											
Hoist & Trolley	(2) Hook wear	Measure "b" and "c" with slide calipers.	NEVER use the hook if dimension "b" or "c" becomes less than 90% of normal.	Replace with new hook if worn.																																											
			 <table border="1" data-bbox="742 907 1465 1209"> <thead> <tr> <th rowspan="2">Capacity (kg or t)</th> <th colspan="2">b (mm)</th> <th colspan="2">c (mm)</th> </tr> <tr> <th>Normal</th> <th>Discard</th> <th>Normal</th> <th>Discard</th> </tr> </thead> <tbody> <tr> <td>125(H),250(S),250(H),500(L),500(S)</td> <td>17.5</td> <td>16</td> <td>23.5</td> <td>21</td> </tr> <tr> <td>1(L), 1(M), 1(S)</td> <td>22.5</td> <td>20</td> <td>31</td> <td>28</td> </tr> <tr> <td>1.5(S)</td> <td>26.5</td> <td>24</td> <td>36.5</td> <td>33</td> </tr> <tr> <td>2(L), 2(M), 2(S)</td> <td>29</td> <td>26</td> <td>40</td> <td>36</td> </tr> <tr> <td>2.5(S)</td> <td>31.5</td> <td>28</td> <td>43.5</td> <td>39</td> </tr> <tr> <td>3(L), 3(S), 3(C)</td> <td>34.5</td> <td>31</td> <td>47.5</td> <td>43</td> </tr> <tr> <td>5(L)</td> <td>42.5</td> <td>38</td> <td>56</td> <td>50</td> </tr> </tbody> </table>	Capacity (kg or t)	b (mm)		c (mm)		Normal	Discard	Normal	Discard	125(H),250(S),250(H),500(L),500(S)	17.5	16	23.5	21	1(L), 1(M), 1(S)	22.5	20	31	28	1.5(S)	26.5	24	36.5	33	2(L), 2(M), 2(S)	29	26	40	36	2.5(S)	31.5	28	43.5	39	3(L), 3(S), 3(C)	34.5	31	47.5	43	5(L)	42.5	38	56	50
Capacity (kg or t)	b (mm)		c (mm)																																												
	Normal	Discard	Normal	Discard																																											
125(H),250(S),250(H),500(L),500(S)	17.5	16	23.5	21																																											
1(L), 1(M), 1(S)	22.5	20	31	28																																											
1.5(S)	26.5	24	36.5	33																																											
2(L), 2(M), 2(S)	29	26	40	36																																											
2.5(S)	31.5	28	43.5	39																																											
3(L), 3(S), 3(C)	34.5	31	47.5	43																																											
5(L)	42.5	38	56	50																																											
	(3) Hook neck deformation	Check visually.	NEVER use bent hook.	Replace with new hook.																																											
	(4) Hook swivel operation	Rotate hook.	Hook turns smoothly.	Replace with new hook if it dose not turn smoothly.																																											
	(5) Upper / lower fitting damage	Check visually.	No damage or deformation. Rivets, bolts and nuts have not loosened or become detached.	Replace with new fittings if damaged or deformed.																																											

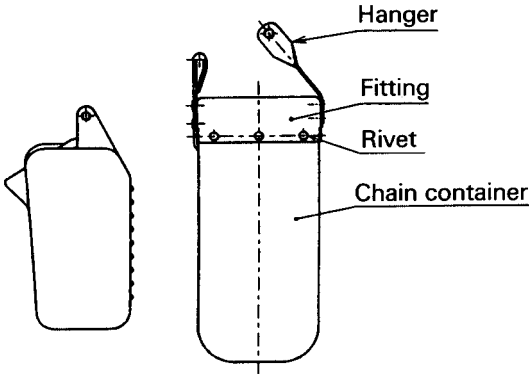
Class	Item	Inspection method	Discard limit/criteria	Remedy																																															
Hoist & Trolley	(6) Rotation of idle sheave	Turn idle sheave by lifting the load chain up and down, as illustrated.	The idle sheave rotates smoothly. 	Inspect and repair if rotation is not smooth.																																															
	(7) Chain container damage	Check visually.	Attachment screws, pins, hangers, fittings, machine screws, chain containers, etc., are not loosened or become detached or damaged. 	Replace with new chain container if damaged.																																															
	(8) Chain container capacity	Measure the chain length.	No foreign matter or dust.	Remove any foreign matter and dust. If the load chain length exceeds the following length in the table, ALWAYS use the larger optional steel chain container.																																															
<table border="1"> <thead> <tr> <th>WLL (kg or t)</th> <th>125(H) 250(S)</th> <th>500(L)</th> <th>250(H) 500(S)</th> <th>1(L) 1(M)</th> <th>1(S)</th> <th>1.5(S) 2(L) 2(M)</th> <th>2(S)</th> <th>2.5(S)</th> <th>3(C)</th> <th>3(L) 3(S)</th> <th>5(L)</th> </tr> </thead> <tbody> <tr> <td rowspan="3">Chain length (m)</td> <td>P</td> <td>6</td> <td>4</td> <td>6</td> <td>4</td> <td>6</td> <td>4</td> <td>-</td> <td>-</td> <td>-</td> <td>-</td> </tr> <tr> <td>S</td> <td>6</td> <td>-</td> <td>8</td> <td></td> <td>8</td> <td>-</td> <td>12</td> <td>8</td> <td>-</td> <td>6</td> </tr> <tr> <td>L</td> <td>12</td> <td>8</td> <td>15</td> <td>8</td> <td>15</td> <td>12</td> <td>18</td> <td>12</td> <td>6</td> <td>8</td> </tr> </tbody> </table> <p>P : Plastic container S : Small container L : Large container</p>		WLL (kg or t)	125(H) 250(S)	500(L)	250(H) 500(S)	1(L) 1(M)	1(S)	1.5(S) 2(L) 2(M)	2(S)	2.5(S)	3(C)	3(L) 3(S)	5(L)	Chain length (m)	P	6	4	6	4	6	4	-	-	-	-	S	6	-	8		8	-	12	8	-	6	L	12	8	15	8	15	12	18	12	6	8				
WLL (kg or t)	125(H) 250(S)	500(L)	250(H) 500(S)	1(L) 1(M)	1(S)	1.5(S) 2(L) 2(M)	2(S)	2.5(S)	3(C)	3(L) 3(S)	5(L)																																								
Chain length (m)	P	6	4	6	4	6	4	-	-	-	-																																								
	S	6	-	8		8	-	12	8	-	6																																								
	L	12	8	15	8	15	12	18	12	6	8																																								

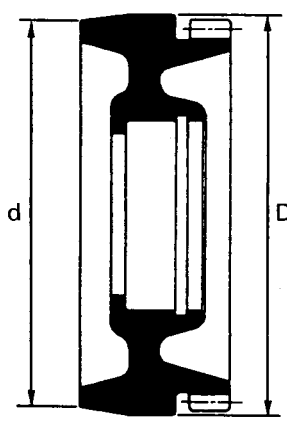
Class	Item	Inspection method	Discard limit/criteria	Remedy	
Hoist & Trolley	1. Power supply fitting				
	(1) Messenger wire tension	Check visually.	Wire dose not sagexcessively.	Tighten to proper tension.	
	(2) Condition of cable hanger	Check visually.	Cable hangers are attached at equal intervals so that cable does not twist. Free of damage and moves smoothly.	Replace defective hangers with new ones.	
	2. Traversing unit				
	(1) Trolley inclination	Run trolley with light load suspended.	Trolley is not tilted when running. If tilted, a wheel may be worn incorrectly.	Adjusting titled trolley	
	(2) Bolts and screws loosening	Check visually.	Each of fitting points are not loosened.	Fasten tightly.	
	(3) Missing snap rings	Check visually.	No snap rings are missing.	Insert snap rings if missing.	
	(4) Wheel abrasion	Measure with slide calipers.	Abrasion of tread and flange do not exceed limits on the table shown below.	Replace with new wheels if limit is exceeded.	
					
	Capacity (kg or t)	Tread outside diameter : D		Tread inside diameter : d	
		Standard	Limit	Standard	Limit
	125kg to 1	95	91	91.5	87.5
	1.5 to 2	110	105	106	101
	2.5, 3	125	118	121	114
	5(L)	140	132	135	127

Class	Item	Inspection method	Discard limit/criteria	Remedy														
Hoist & Trolley	(5) Side plate deformation	Check visually or with slide calipers, as necessary.	No obvious deformation must be evident.	If damaged obviously, replace it with a new side plate.														
	(6) Suspension shaft deformation and abrasion	Check visually or with slide calipers as necessary.	NEVER use a suspension shaft if bent. NEVER use a suspension shaft if its diameter is worn down 10% or more.	Replace with new suspension shaft.														
	(7) Movement of joint fittings	Move electric chain hoist back and forth and right and left.	Joint fittings move smoothly.	If the movement is not smooth, supply oil to the top pin.														
	(8) Side roller wear	Check visually or with slide calipers, as necessary.	Compact part of the side roller is not worn to exceed limit dimensions on the table shown below.	Replace with new rollers if abrasion exceeds limit.														
		Move rollers by hand.	Rollers rotate smoothly.	Supply oil to roller shafts occasionally.														
			<table border="1"> <thead> <tr> <th rowspan="2">Capacity (kg or t)</th> <th colspan="2">Outside diameter (mm)</th> </tr> <tr> <th>Standard</th> <th>Limit</th> </tr> </thead> <tbody> <tr> <td>125kg to 1</td> <td>38</td> <td>37</td> </tr> <tr> <td>1.5 to 3</td> <td>43</td> <td>42</td> </tr> <tr> <td>5(L)</td> <td>55</td> <td>54</td> </tr> </tbody> </table>	Capacity (kg or t)	Outside diameter (mm)		Standard	Limit	125kg to 1	38	37	1.5 to 3	43	42	5(L)	55	54	
Capacity (kg or t)	Outside diameter (mm)																	
	Standard	Limit																
125kg to 1	38	37																
1.5 to 3	43	42																
5(L)	55	54																
	(9) Split pins damaged for shaft stopper pins and missing split pins	Check visually.	Split pins are not damaged by rust or wear. Split pins should not be missing.	Replace with new pins if thinned. Insert split pins if missing.														

8. TROUBLESHOOTING

Situation	Cause	Explanation	Remedy
Moves in the reverse direction.	Reversed connection.	Connect correctly two lead wires of three wires for power supply.	See 5.3 "Trial run".
Won't move.	(1) Blown power circuit fuse or the power circuit breaker is switched off. (2) Blown control circuit fuse. (3) Disconnection of power cable or; disconnection of push button cord (5) Voltage drop (6) The emergency stop button was pushed. (7) Trouble in the internal wiring (loose contact, disconnection) (8) Damaged contact in electromagnetic contactor	Replace the fuse. Check current rating is correct. Replace the fuse or reset the breaker switch as necessary. Replace the fuse. Check current rating is correct and replace fuse as necessary/ Check for disconnection in cable or cord which are subjected to frequent bending, and repair disconnected point. Check voltage with a tester, and check connecting condition at the power source. Turn the emergency stop button to the right to release. Check internal wiring and repair where necessary. Replace the electromagnetic contactor.	If motor hums and does not rotate, stop operation immediately.
Won't stop.	Welded contacts in electromagnetic contactor	Replace the electromagnetic contactor.	
Brake slips.	Abrasion of motor brake	Check and repair the motor brake.	
Load fails to rise.	(1) Trouble with the friction clutch (2) voltage drop	Contact KITO or an authorized KITO dealer. Check voltage with a tester, and check connecting condition at the power source.	If motor hums and does not rotate, stop operation immediately.
Abnormal sound come from load chain	(1) Trouble with the friction clutch (2) Worn load sheave	Supply oil to load chain. Replace the load sheave.	Wear limit for chain link diameter at the gearing part of chain is 10%. Total wear limit for every 5 links pitch is 3%.
The trolley does not stop immediately	Loose trolley motor brake	Check and repair the motor brake.	Keep braking time to less than 1 second.
The trolley wheels slip.	(1) Tilted rail (2) Excessive oil on tread of traversing rail	Check and correct rail tilting. Wipe off oil.	Slightly grease the tread for better result.
Electric shock	(1) Improper grounding work (2) Accumulated foreign matter or moisture on electric parts	Provide correct grounding. Remove foreign matters or dry whole electric parts completely.	Ground equipment according to local laws. The traversing rail may serve as a grounding conductor when four conductors cable is not used for power supply to the motorized trolley. Be sure to ground the rail in this case.
Oil leak	(1) No oil plug (2) Loose fitting or oil plug (3) No plug packing (4) Worn or deteriorated oil packing	Attach the normal oil plug. Fasten the plug tightly. Attach normal packing. Replace with new packing.	

9. WARRANTY

KITO Corporation ("KITO") extends the following warranty to the original purchaser ("Purchaser") of new products manufactured by "KITO" (KITO's Products).

- (1) "KITO" warrants that KITO's Products, when shipped, shall be free from defects in workmanship and/or materials under normal use and service and "KITO" shall, at the election of "KITO", repair or replace free of charge any parts or items which are proven to have said defects, provided that all claims for defects under this warranty shall be made in writing immediately upon discovery and, in any event, within one (1) year from the date of purchase of KITO's Products by "Purchaser" and provided, further, that defective parts or items shall be kept for examination by "KITO" or its authorized agents or returned to KITO's factory or authorized service center upon request by "KITO".
- (2) "KITO" does not warrant components of products provided by other manufacturers. However to the extent possible, "KITO" will assign to "Purchaser" applicable warranties of such other manufacturers.
- (3) Except for the repair or replacement mentioned in (1) above which is "KITO"'s sole liability and purchaser's exclusive remedy under this warranty, "KITO" shall not be responsible for any other claims arising out of the purchase and use of KITO's Products, regardless of whether "Purchaser"'s claims are based on breach of contract, tort or other theories, including claims for any damages whether direct, indirect incidental or consequential.
- (4) This warranty is conditional upon the installation, maintenance and use of KITO's Products pursuant to the product manuals prepared in accordance with content instructions by "KITO". This warranty shall not apply to KITO's Products which have been subject to negligence, misuse, abuse, misapplication or any improper use or combination or improper fittings, alignment or maintenance.
- (5) "KITO" shall not be responsible for any loss or damage caused by transportation, prolonged or improper storage or normal wear and tear of KITO's Products or for loss of operating time.
- (6) This warranty shall not apply to KITO's Products which have been fitted with or repaired with parts, components or items not supplied or approved by "KITO" or which have been modified or altered.

THIS WARRANTY IS IN LIEU OF ALL OTHER WARRANTIES. EXPRESS OR IMPLIED, INCLUDING BUT NOT LIMITED TO ANY WARRANTY OF MERCHANTABILITY OR OF FITNESS FOR A PARTICULAR PURPOSE.



KITO CORP.

3-37-4, Yoyogi, Shibuya-ku,
Tokyo 151-0053, Japan
Tel. : 03-5371-7341
Fax. : 03-5371-7349
Tlx. : 222-2942 KITO J
E-mail : overseas@kito.co.jp
URL : <http://www.kito.co.jp>

KITO CANADA INC.
CHAIN HOISTS

309-3815 1ST AVENUE
BURNABY, BC V5C 3V6
Ph : (604) 291-9955
Fx : (604) 294-8855
E-mail : info@kito.ca
URL : <http://www.kito.ca/>